

ELECTRONIC DEVICES AND CIRCUITS

(CODE - EEE - 218)



LABORATORY MANUAL

DEPARTMENT OF ELECTRONICS & COMMUNICATION ENGINEERING

ANIL NEERUKONDA INSTITUTE OF TECHNOLOGY & SCIENCES

(Affiliated to Andhra University)

Sangivalasa-531162, Bheemunipatnam Mandal, Visakhapatnam

Phone:089335084,226395

ANIL NEERUKONDA INSTITUTE OF TECHNOLOGY & SCIENCES
(Affiliated to AU, Approved by AICTE & Accredited by NBA)
SANGIVALASA-531 162, Bheemunipatnam Mandal, Visakhapatnam District
Phone: 08933-225083/84/87 Fax: 226395
**DEPARTMENT OF ELECTRONICS AND COMMUNICATION
ENGINEERING**

**ELECTRONIC DEVICES & CIRCUITS
LABORATORY MANUAL (EEE-218)
(II/IV EEE 1st Semester)**



ANITS

Prepared By:

Prepared by:

**Ms.V.Shireesha
Assistant Professor,
Department of ECE.**

Approved By:

**Dr.V.Rajya Lakshmi,
Professor & HOD,
Department of ECE,ANITS**

ELECTRONIC DEVICES & CIRCUITS LABORATORY

EEE 218

Instruction: 3 practicals/week

End Exam : 3 Hours

Credits: 2

Sessional Marks: 50

Exam Marks : 50

COURSE OBJECTIVES

- To observe the characteristics of different diodes and transistors practically.
- To Design and construct simple electronic circuits to accomplish a specific function, e.g. designing rectifiers, designing amplifiers etc.

COURSE OUTCOMES:

At the end of the course the student will be able to:	
1.	Understand the use of RPS and CRT.
2.	Verify the working of diodes, transistors and their applications.
3.	Set up a bias point in a transistor.
4.	Design simple hardware circuits using diodes and transistors.
5.	Design simple DC power supply circuits.

CO-PO Mapping of EDC Laboratory:

CO	PO1	PO2	PO3	PO4	PO5	PO6	PO7	PO8	PO9	PO10	PO11	PO12
CO1		1	2	3		1			2	1		
CO2	1	1				1			1	1		
CO3	3	1	1	2		1			1	1		
CO4	1	1	2	3		1			1	1		
CO5	1	1				1			1	1		

ELECTRONIC DEVICES AND CIRCUITS LABORATORY (EEE- 218)

- 1. STUDY OF CRO AND APPLICATIONS**
- 2. V-I CHARACTERISTICS OF P- N JUNCTION DIODE**
- 3. V-I CHARACTERISTICS OF A ZENER DIODE & ZENER REGULATOR CHARACTERISTICS**
- 4. V-I CHARACTERISTICS OF LIGHT EMITTING DIODE (LED)**
- 5. HALF WAVE RECTIFIER WITHOUT AND WITH FILTER**
- 6. FULL WAVE RECTIFIER WITHOUT AND WITH FILTER**
- 7. CHARACTERISTICS OF BJT IN CB CONFIGURATION, h-PARAMETERS**
- 8. CHARACTERISTICS OF BJT IN CE CONFIGURATION, h-PARAMETERS**
- 9. CHARACTERISTICS OF BJT IN CC CONFIGURATION, h-PARAMETERS**
- 10. DRAIN AND TRANSFER CHARACTERISTICS OF JUNCTION FIELD EFFECT TRANSISTOR (JFET)**
- 11. TRANSISTOR AS A SWITCH**
- 12. IMPLEMENTATION OF LOGIC GATES USING DIODES AND TRANSISTORS**
- 13. SCR CHARACTERISTICS**
- 14. UJT CHARACTERISTICS**

1. STUDY OF CATHODE RAY OSCILLOSCOPE AND APPLICATIONS

AIM: To study the front & back panels of a cathode ray oscilloscope.

APPARATUS:

Cathode ray oscilloscope,
Audio frequency probe or audio frequency generator,
connecting wires.

THEORY: CRO is an electronic device which is capable of giving a visual indication of a signal waveform. With an oscilloscope the waveform of the signal can be studied with

Respect to amplitude distortion and deviation from the normal. Oscilloscope can also be used for measuring voltage, frequency and phase shift.

Cathode Ray Tube: Cathode Ray Tube is a heart of Oscilloscope providing visual display of the input signals. CRT consists of three basic parts.

1. Electron Gun.
2. Deflecting System.
3. Fluorescent Screen

These essential parts are arranged inside a tunnel shaped glass envelope.

Electron Gun: The function of this is to provide a sharply focused stream of electrons. It mainly consists of an indirectly heated cathode, a control grid, focusing anode and accelerating anode. Control grid is cylinder in shape. It is connected to negative voltage w.r.t to cathode. Focusing and accelerating anodes are at high positive potential. w.r.t anode. Cathode is indirectly heated type & is heated by filament. Plenty of electrons are released from the surface of cathode due to Barium Oxide coating. Control Grid encloses the cathode and controls the number of electrons passing through the tube.

A voltage on the control grid consists the cathode determines the number of electrons freed by heating which are allowed to continue moving towards the face of the tube. The accelerated anode is heated at much higher potential than focusing anode. Because of this reason the accelerating anode accelerates the light beam into high velocity. The beam when strikes the screen produces the spot or visible light.

The name electron Gun is used because it fires the electrons like a gun that fires a bullet.

Deflection system: The beam after coming out of the accelerated anode passes through two sets of deflection plates with the tube . The first set is the vertical deflection plate and the second set is horizontal deflection plates. The vertical deflection plates are oriented to deflect the electron beam that moves vertically up and down. The direction of the vertical deflection beam is determined by the voltage polarity applied to the plates. The amount of deflection is set by the magnitude of the applied voltage. The beam is also deflected horizontally left or

right by a voltage applied to horizontal plates. The deflecting beam is then further accelerated by a very high voltage applied to the tube.

Fluorescent Screen: The screen is large inside the face of the tube and is coated with a thin layer of fluorescent material called Phosphor. On this fluorescent material when high velocity electron beam strikes it converting the energy of the electron the electron beam between into visible light(spots). Hence the name is given as fluorescent screen.

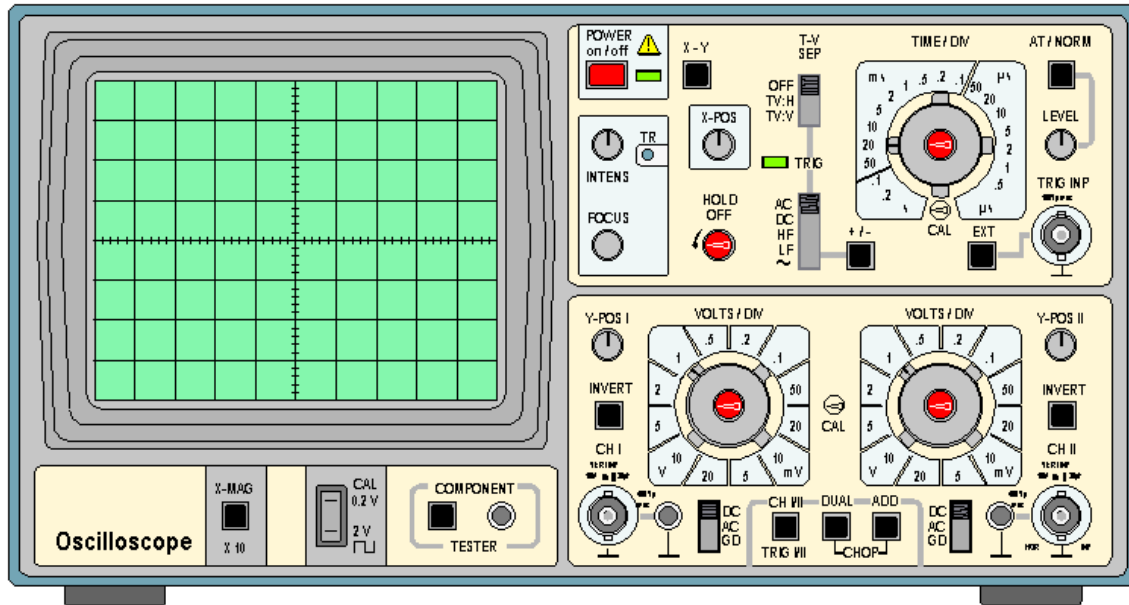

FRONT PANEL OF CATHODE RAY OSCILLOSCOPE(CRO)

PANEL CONTROLS:

- 1. POWER ON/OFF** : Push the button switch to supply power to the instrument.
- 2. X5** : Switch when pushed inwards gives 5 times magnification of the X signal
- 3. XY** : Switched when pressed cut off the time base and allows access the exit horizontal signal to be fed through CH II
(used for XY display).
- 4. CH I/CH II/TRIG I/ TRIG II** : Switch out when selects and triggers CH I and when pressed selects and triggers CH II.
- 5. MOO/DUEL** : Switch when selects the dual operation switch
- 6. ALT/CHOP/ADD** : Switch selects alternate or chopped in dual mode. If mode is selected then this switch enables addition or subtraction of the channel i.e. CH-I +/- CH-II.
- 7. TIME/DIV** : Switch selects the time base speed.
- 8. AT/NORM** : Switch selects AUTO/NORMAL position .Auto is used to get trace when no signal is fed at the input. In NORM the trigger level can be varied from the positive peak to negative peak with level control.
- 9. LEVEL** : Controls the trigger level from the peak to peak

- amplitude signal.
- 10. TRIG.INP** : Socket provided to feed the external trigger signal in EXT. mode.
 - 11. CAL OUT** : Socket provided for the square wave output 200 mv used for probe compensation and checking vertical sensitivity etc.
 - 12. EXT** : Switch when pressed allows external triggering signal to be fed from the socket marked TRIG.INP.
 - 13. X-POS** : Controls the horizontal position of the trace.
 - 14. VAR** : Controls the time speed in between two steps of time/div switch .For calibration put this fully anticlockwise (at cal pos)
 - 15. TV** : Switch when it allows video frequency upto 20 KHz to be locked.
 - 16. + -** : Switch selects the slope of trigger whether positive going or negative.
 - 17. INV CHJ II** : Switch when pressed inverts the CH ii.
 - 18. INTENS** : Controls brightness of trace.
 - 19. TR** : Controls the alignment of the trace with gratitude (screw driver adjustment).
 - 20. FOCUS** : Controls the sharpness of the trace.
 - 21. CT** : Switch when pressed starts CT operation.
 - 22. GD/AC /DC** : Input coupling switch for each channel. In AC the signal is coupled through the 0.1MFD capacitor.
 - 23. DC/AC/GD** : BNC connectors serve as input connectors for the CH I and CH II channel input connector also serves as the horizontal external signal.
 - 24. CT-IN** : To test any components in the circuit, put one test probe in this socket and connect the other test probe in the ground socket.
 - 25. VOLTS /DIV** : Switches select the sensitivity of each channel.
 - 26. Y POS I AND II** : Controls provided for vertical deflection for each channel.

BACK PANEL CONTROLS

- 1. FUSE** : 350 mA fuse is provided at the back panel spare fuses are provided inside the instrument.
- 2. ZMOD** : Banana socket provided for modulating signal input i.e. Z-modulation.

PROCEDURE:

1. Turn on the power.
2. In function generator required frequency & voltage is set. Press the SINE Button to get the Sinusoidal waveform.
3. In CRO the sine wave is adjusted The amplitude of the wave is obtained from the vertical axis.If required use multiplication factor to find the appropriate Voltage.
4. Time period is calculated from X-axis.

5. Frequency is obtained by formula $F=1/T$.
6. This frequency is compared with the frequency applied.
7. Voltage in the CRO is compared with the voltage applied from function generator.
8. By repeating the above steps we can find frequency and voltages of square wave & triangular waves can be calculated.

PRECAUTIONS

1. Avoid using CRO in high ambient light conditions.
2. Select the location free from Temperature & humidity. It should not be used in dusty environment.
3. Do not operate in a place where mechanical vibrations are more or in a place which generates strong magnetic fields or impulses.
5. Do not increase the brightness of the CRO than that is required.

RESULT: The Front and Back Panels of CRO are studied.

VIVA QUESTIONS:

1. What is the function of horizontal and vertical deflection coil?
2. What type of deflection is used in CRO?
3. Explain Front Panel of CRO.
4. What is the function of Triggering?
5. Draw CRT diagram.

PREPARED BY	CHECKED BY	H.O.D
-------------	------------	-------

2. V-I CHARACTERISTICS OF PN JUNCTION DIODE

AIM: To plot the V-I characteristics of PN junction diode in forward and reverse bias and also to calculate Static and Dynamic Resistance.

APPARATUS:

1. IN4007 Diode.
2. 470 Ω resistor.
3. 1K Ω resistor.
4. Ammeter (0-100mA).
5. Ammeter (0-100 μ A).
6. Voltmeter (0-2V).
7. Voltmeter (0-30V).
8. TRPS (0-30V).
9. Bread Board.
10. Connecting wires.

CIRCUIT DIAGRAM:

Forward Bias:

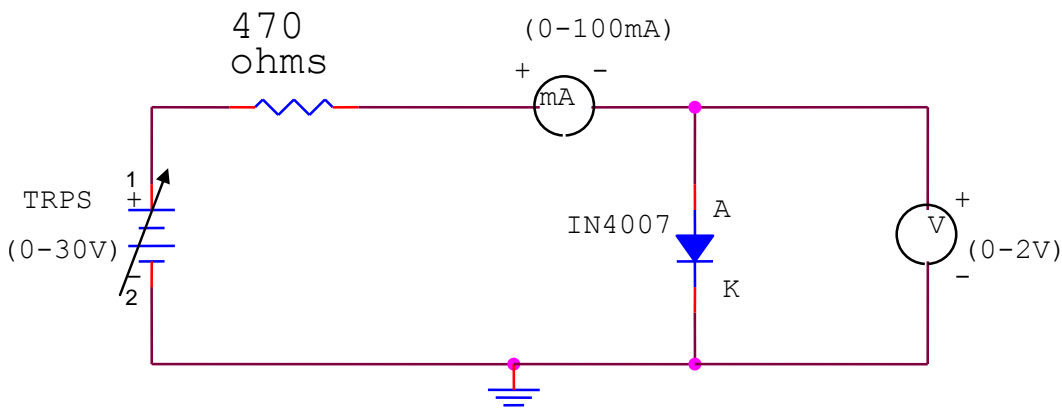

Reverse Bias

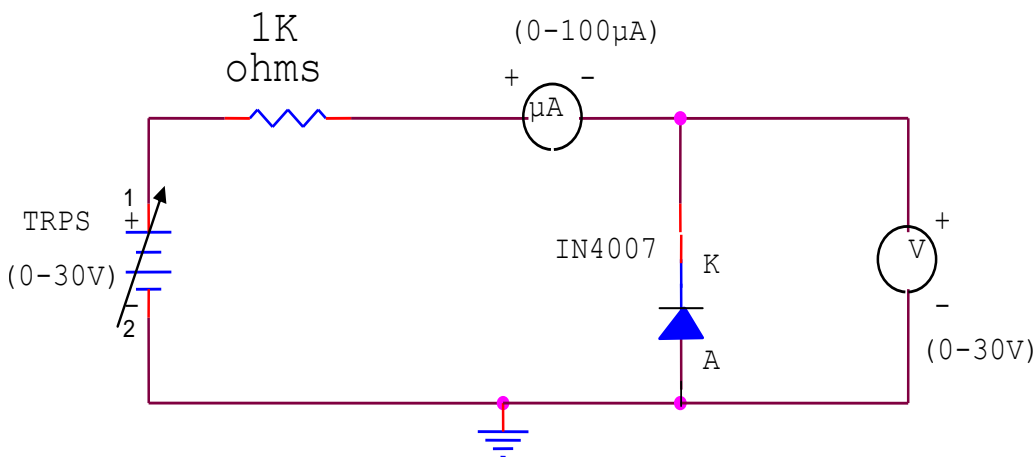

TABULAR FORMS:

Forward bias:

V_S (Volts)	V_f (Volts)	I_f (mA)

Reverse bias:

V_S (Volts)	V_r (Volts)	I_r (μA)

MODEL GRAPH:

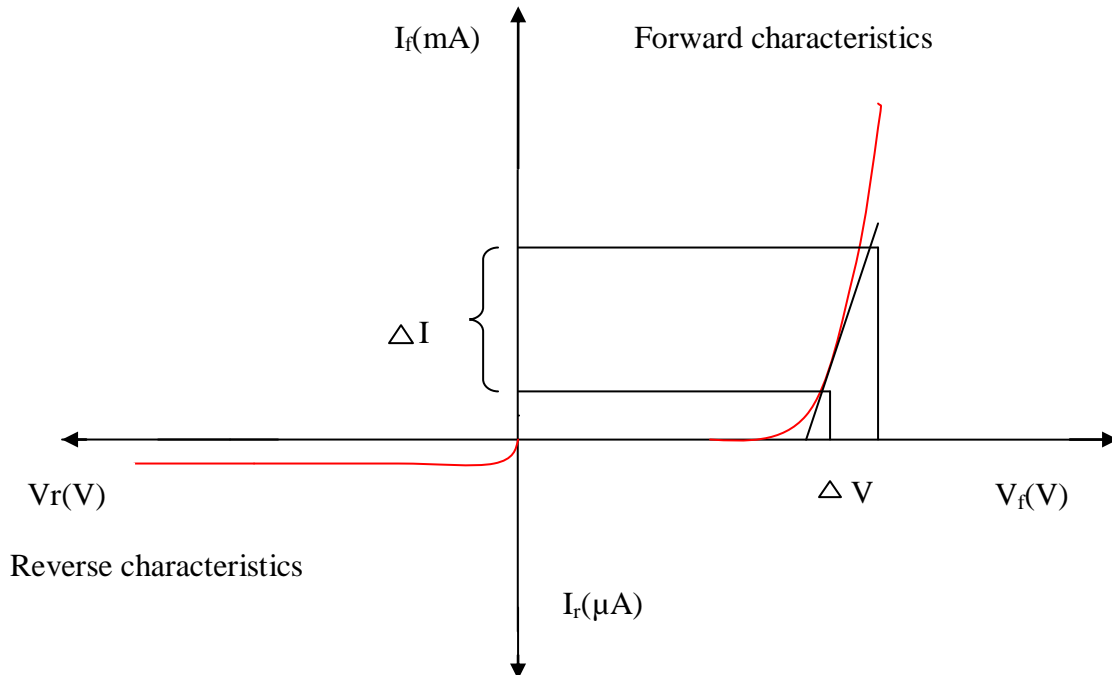

PROCEDURE:

Forward bias:

1. Make the Connections according to circuit diagram.
2. In forward bias, connect the positive end of battery to Anode and negative end of the battery to Cathode of diode.
3. By varying the input voltage in steps of 0.1V, note corresponding Voltmeter and Ammeter readings.
4. Plot the graph between forward voltage (V_f) and forward current (I_f).

Reverse bias:

1. Make the Connections according to circuit diagram.
2. In reverse bias, connect the positive end of battery to Cathode and negative end of the battery to Anode of diode.
3. By varying the note corresponding Voltmeter and Ammeter readings.
4. Plot the graph between Reverse voltage (V_r) and Reverse current (I_r).

CALCULATIONS:

- i. Static resistance = V / I at Q-point
- ii. Dynamic resistance = $\Delta V / \Delta I$ at Q-point

PRECAUTIONS:

1. Connections must be made carefully to avoid short circuit.
2. Readings must be taken without parallel ox error

RESULT:

The V-I Characteristics of a pn-diode are observed and the graphs are plotted. And the values obtained from the graph are

1. Static resistance =
2. Dynamic resistance=
3. Cut-in Voltage =

VIVA QUESTIONS:

1. When diode acts like ideal switch?
2. What is the cut in voltage? And give the typical values for Ge and Si.
3. What is reverse saturation current?
4. What is Dynamic and static resistance?
5. What is V-I characteristics equation?
6. What is depletion layer?
7. What are P type and N type materials? And what IN4007 Diode, OA79 Diode indicates?
8. What is the effect of temperature on I_{co} , V_e ?
9. What is Q point?

PREPARED BY	CHECKED BY	H.O.D
-------------	------------	-------

3. V-I CHARACTERISTICS OF ZENER DIODE AND ZENER DIODE REGULATOR

AIM: To plot the V-I characteristics of Zener Diode in reverse bias and to verify that Zener Diode acts as a Voltage Regulator.

APPARATUS:

1. Zener diode IMZ5.1 V.
2. 470Ω resistor.
3. Ammeter (0-50mA).
4. Voltmeter (0-10V).
5. TRPS (0-30V).
6. Bread Board.
7. Decade Resistance Box (DRB).
8. Connecting Wires.

CIRCUIT DIAGRAM:

Reverse bias characteristics:

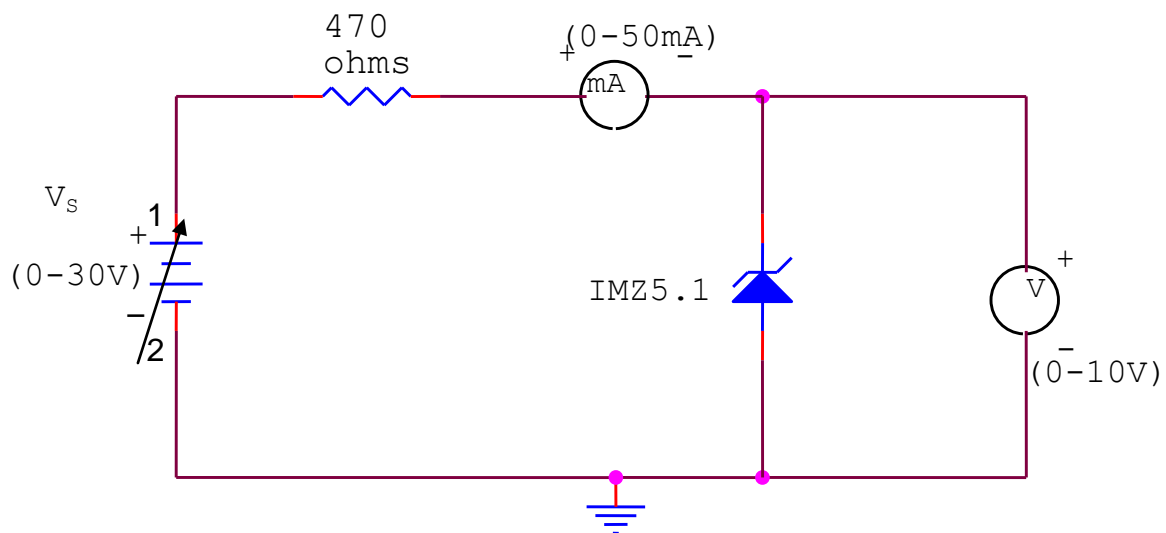

PROCEDURE:

a) To Plot V-I Characteristics

1. Make the connections as shown in the circuit diagram.
2. Vary the RPS voltage from 0V to 30V in steps of 1V.
3. Tabulate the readings of Ammeter (I_Z) and Voltmeter (V_Z).
4. Plot the graph between V_Z & I_Z .
5. Calculate the break down voltage of given zener diode from the graph

TABULAR FORM: (V-I Characteristics)

S.No.	V_s (Volts)	V_z (Volts)	I_z (mA)

MODEL GRAPH:

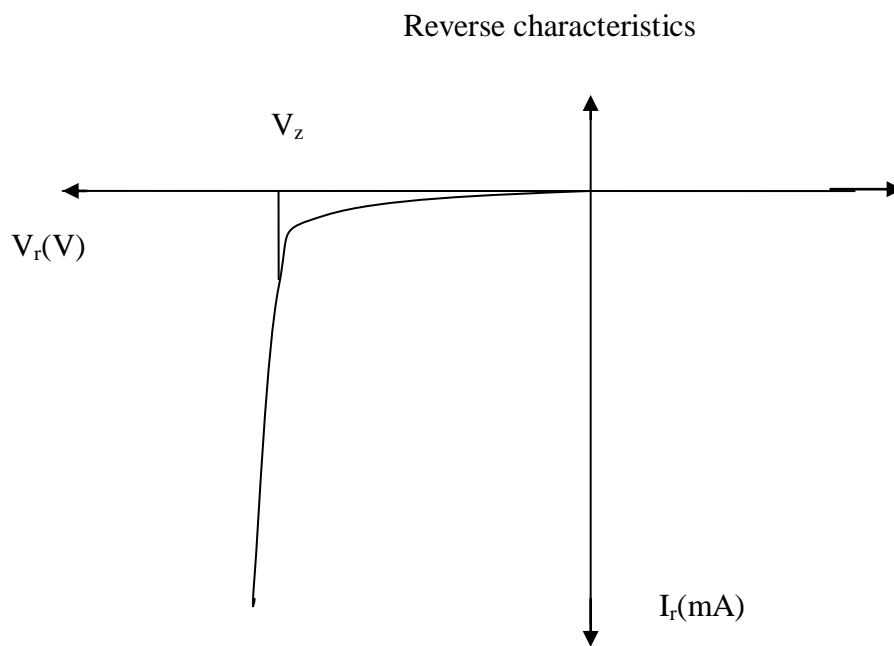

CIRCUIT DIAGRAM:

Zener diode as Voltage Regulator:

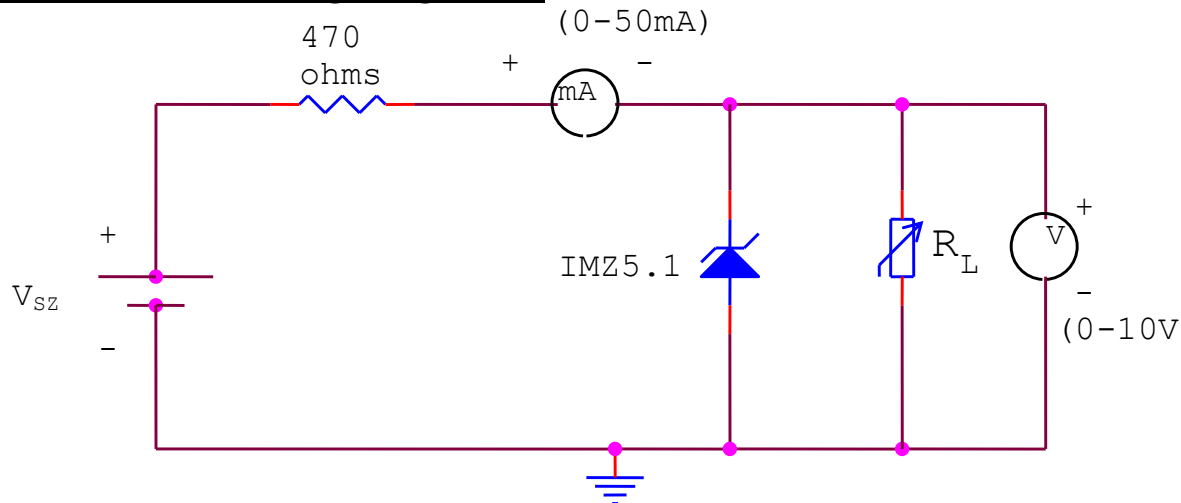

TABULAR FORM: (Regulation Characteristics)

$V_{NL} = \dots\dots\dots$

S.No.	R_L (ohms)	V_L (Volts)	$I_S = (I_Z + I_L)$ (mA)	% Regulation $((V_{NL} - V_L) / V_L) \times 100$
	1100 Ω to 100 Ω			

PROCEDURE:

b) As Voltage Regulator:

1. Make the connections as shown in figure 2.
2. Measure V_{NL} (No load voltage) by opening the load resistance.
3. Connect the load resistance, and vary the load resistance from 1100 Ω to 100 Ω in steps of 100 Ω and note down the readings of Voltmeter (V_Z) and Ammeter (I_S).
4. Calculate % Regulation by using the formula given below.

%Regulation = $((V_{NL} - V_L) / V_L) \times 100$

MODEL GRAPH:

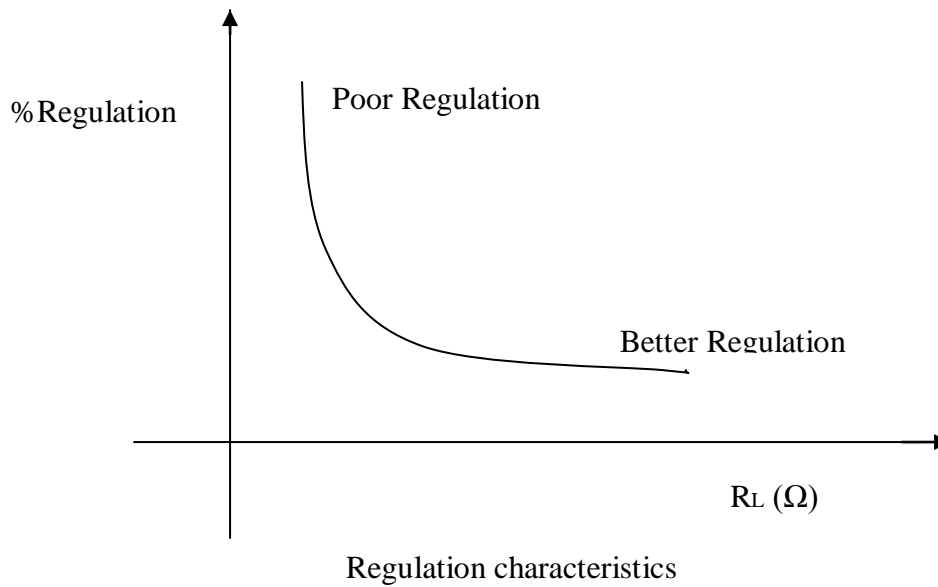

PRECAUTIONS:

1. Connections must be made carefully to avoid short circuit.
2. Readings must be taken without parallax error.
3. The readings should not exceed meter range.

- RESULT:**
1. The reverse bias characteristics of Zener diode are observed and the graph was plotted. And the breakdown voltage was obtained from the graph.
 2. The Regulation characteristics of a Zener Diode are observed and the graph was plotted.

VIVA QUESTIONS:

1. Difference between Zener and Avalanche breakdown.
2. What is the difference between zener and ordinary diode?
3. Draw equivalent circuit for Zener diode.
4. What is Breakdown voltage?
5. What are the applications of zener diode?
6. How zener acts as a regulator?
7. What does IMZ5.1V indicates?

PREPARED BY	CHECKED BY	H.O.D
-------------	------------	-------

4. V-I CHARACTERISTICS of LIGHT EMITTING DIODE (LED)

AIM: To determine the forward bias characteristics of the light emitting diode (LED).

APPARATUS:

1. L.E.D
2. 470Ω resistor
3. Ammeter (0-100ma)
4. Voltmeter (0-20v)
5. TRPS
6. Bread board
7. Connecting wires

CIRCUIT DIAGRAM

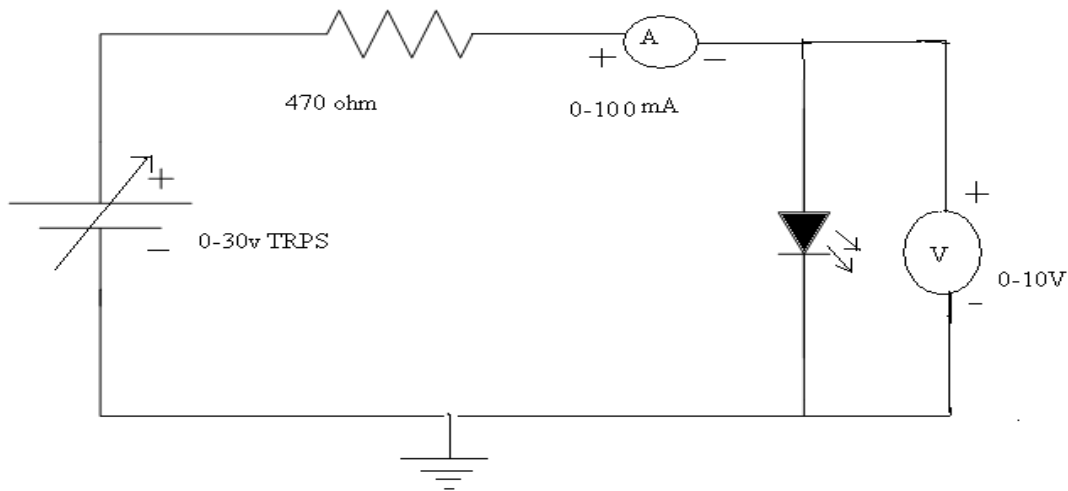

PROCEDURE

1. Connections must be made as per the circuit diagram.
2. By varying the voltage in steps corresponding current in the ammeter is noted.
3. At the same time the glow intensity of the light emitting diode is also to be noted.
4. Taking voltage on X-axis and current on Y-axis that gives the forward bias V-characteristics, plot a graph.

TABULAR FORM:

S.NO	$V_S(V)$	$V_F(V)$	$I_f(mA)$	Intensity of glow

MODEL GRAPH:

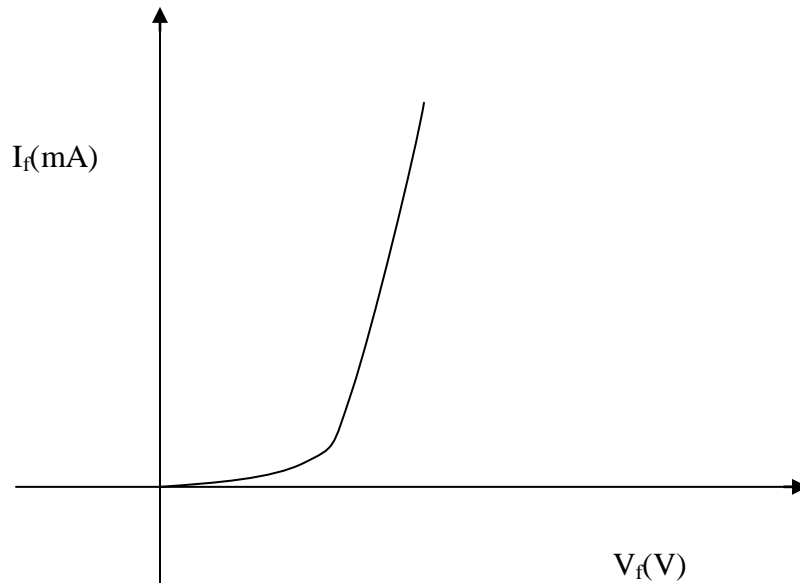

PRECAUTIONS:

1. Connections must be made carefully to avoid short circuit.
2. Readings must be taken without parallel-ox error.
3. Readings should not exceed meter range.

RESULT: The forward characteristics of a light emitting diode are obtained and the graph was plotted.

VIVA QUESTIONS:

1. What is LED?
2. Which materials are used in manufacturing of LEDs?
3. What are the applications of LEDs?
4. How LED is different from ordinary diode?
5. What is the difference between direct band gap and indirect bandgap semiconductor?

PREPARED BY	CHECKED BY	H.O.D
-------------	------------	-------

5. HALF WAVE RECTIFIER WITHOUT AND WITH FILTER

AIM: To observe the output waveforms and to find ripple Factor of a Half Wave Rectifier with and without filter.

- APPARATUS:**
1. 0-12V Step down Transformer – 1no.
 2. IN 4007 Diode – 1no.
 3. 0-30V Voltmeter or Millimeter/DMM – 1no.
 4. 1000Ω resistor – 1no.
 5. 1000μf/25V capacitor – 1no.
 6. Bread Board.
 7. Connecting wires.

CIRCUIT DIAGRAM:

Half Wave Rectifier Without Filter:

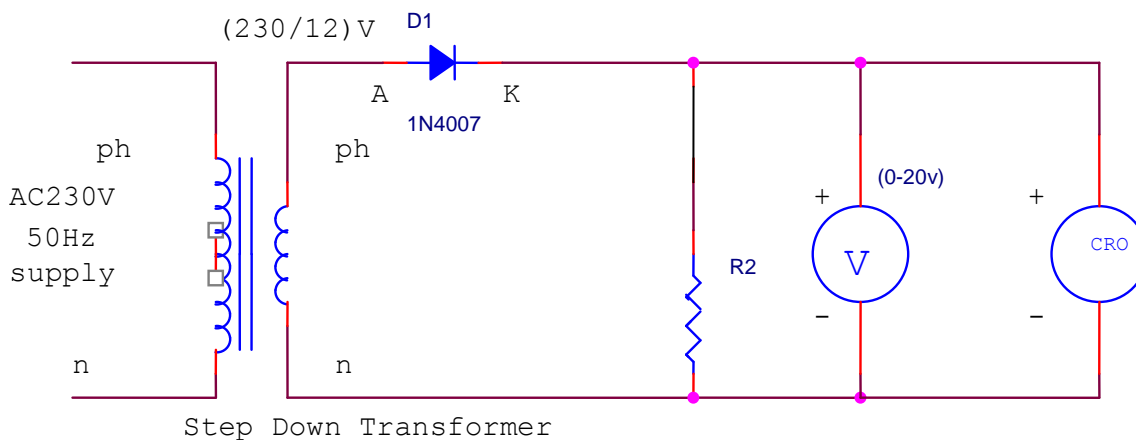

TABULAR FORM:

Without filter:

1) Using CRO

V_m (V)	$V_{dc} = V_m / \pi$ (V)	$V_{rms} = V_m / 2$ (V)	$V_{r(rms)} =$ $\sqrt{(V_{rms}^2 - V_{dc}^2)}$ (V)	R.F = $V_{r(rms)} / V_{dc}$

2.Using DMM:

V_{AC}	V_{DC}	$R.F=V_{AC}/V_{DC}$

CIRCUIT DIAGRAM:

Half Wave Rectifier With Filter:

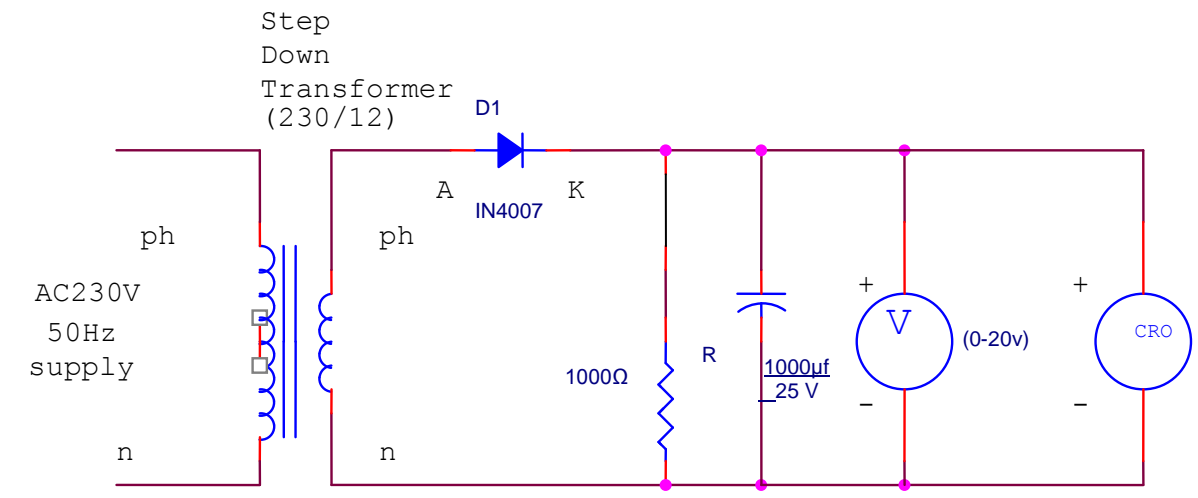

TABULAR FORM:

With filter:

1. Using CRO

V_r (V)	V_m (V)	$V_{dc} = V_m - V_r/2$	V_r (rms) = $V_r / 2\sqrt{3}$	$R.F = V_r$ (rms) / V_{dc}

2. Using DMM:

V_{AC}	V_{DC}	$R.F=V_{AC}/V_{DC}$

PROCEDURE: With & Without Filter:

1. Connections are made as per the circuit diagram.
2. Observe the output waveform on CRO. Note down the peak voltage value V_M .
3. Using DMM/multimeter down the AC voltage and DC voltage.
4. Now calculate V_{dc} , V_{rms} , Ripple Factor and other parameters of Half wave rectifier according to the formulae.
5. Now connect a shunt capacitor and repeat the above process.
6. For with filter put CRO in ac mode, and find out the value of V_r . And calculate V_{dc} and $V_{r(rms)}$ and other parameters.
7. Plot the graphs.

MODEL GRAPHS:

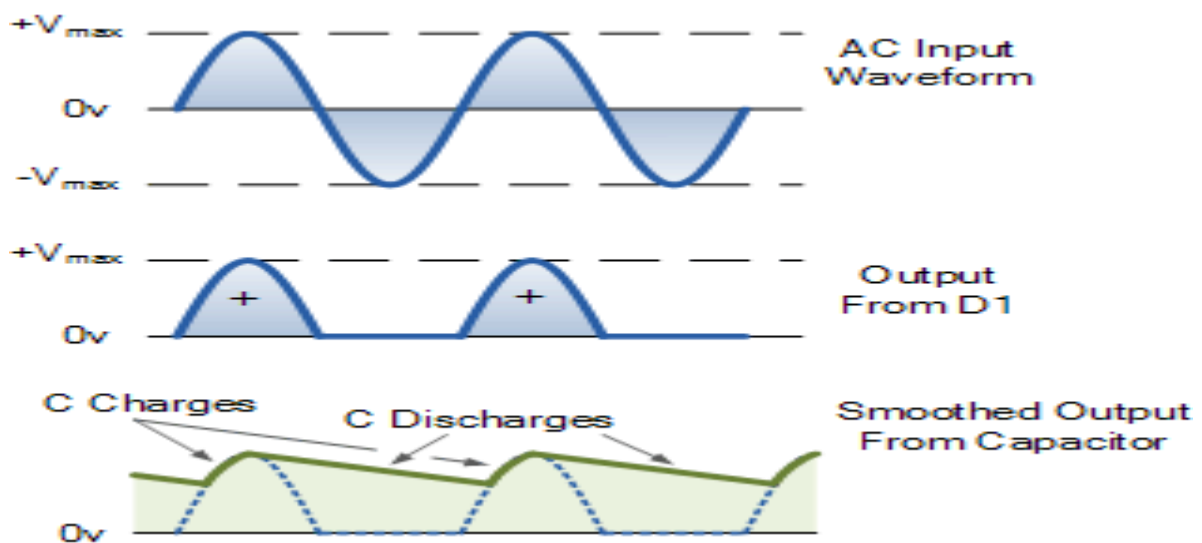

CALCULATIONS:

Without filter:

1. $V_{dc} = V_m / \pi$
2. $V_{rms} = V_m / 2$
3. $V_{r(rms)} = \sqrt{V_{rms}^2 - V_{dc}^2}$
4. $\text{Ripple Factor} = V_{r(rms)} / V_{dc}$

With filter:

1. $V_{dc} = V_m - V_r/2$
2. $V_{r(rms)} = V_r / 2\sqrt{3}$
3. $\text{Ripple Factor} = V_{r(rms)} / V_{dc}$

Theoretical Calculations:

$$\text{Ripple factor} = 1/(2\sqrt{3fRC})$$

PRECAUTIONS:

1. Connections must be made carefully to avoid short circuit.
2. Readings must be taken without parallel or error.

RESULT: The output waveforms are observed and Ripple factor of a Half wave rectifier with filter and without filter are obtained as

1. Ripple factor of Half wave rectifier without filter =
2. Ripple factor of Half wave rectifier with filter =

VIVA QUESTIONS:

1. What is rectifier?
2. What is filter?
3. Define Ripple factor. What is the ripple factor value of rectifier with & without filter?
4. What is Peak inverse voltage? Give the value of PIV for half wave rectifier.
5. How capacitor acts as filter?
6. Give the efficiency & Ripple frequency output with and without filter.

PREPARED BY	CHECKED BY	H.O.D
-------------	------------	-------

6. FULL WAVE RECTIFIER WITH & WITHOUT FILTER

AIM: To observe the output waveform and to find ripple factor of the center tapped full wave rectifier.

APPARATUS:

1. Center tapped Step down transformer
2. IN4007 diodes –2
3. Resistor 1000Ω
4. $1000\mu\text{f}/25\text{v}$ capacitor
5. Voltmeter (0-20v)
6. Bread board.
7. Connecting wires.

THEORY:

In this the circuit has 2 diodes D_1 & D_2 as shown .A center tapped secondary winding AB is used with diodes connected so that each uses one half of the input voltage. During positive half cycle, voltage polarities are shown, D_1 is in forward bias and D_2 is in reverse bias and hence current flows through D_1 acts as short circuit. The current in negative half cycle flows through D_2 and D_1 acts as open circuit. The current in both half cycles through the load is in same direction. Therefore dc output across the load resistance should be noted. V_m is the maximum voltage across secondary winding since at any time one diode conducts and while other doesn't. The whole secondary voltage would appear across non conducting diode consequently peak inverse voltage ($\text{PIV}=2V_m$).A filter circuit is a device which removes a.c component of output. It consists of a capacitor placed across rectifier output in parallel with load R_L .

CIRCUIT DIAGRAM:

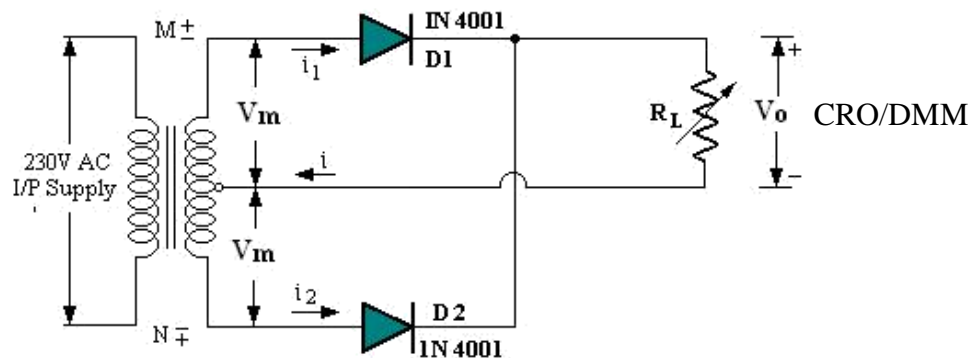

Full-wave Rectifier without filter

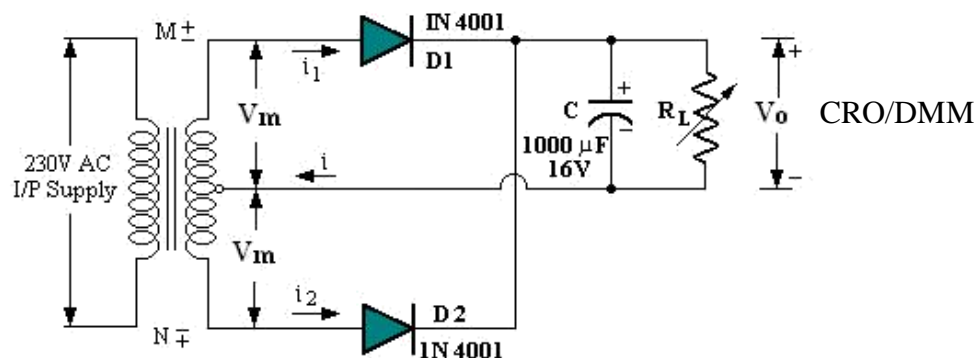

Full-wave Rectifier with capacitor filter

**TABULAR FORM:
WITHOUT FILTER:
1) Using CRO**

V_m (V)	$V_{dc} =$ $2V_m / \pi$ (V)	$V_{rms} =$ $V_m / \sqrt{2}$ (V)	$V_{r(rms)} =$ $\sqrt{(V_{rms}^2 - V_{dc}^2)}$ (V)	R.F = $V_{r(rms)} / V_{dc}$

2) Using DMM:

V_{AC}	V_{DC}	R.F = V_{AC} / V_{DC}

WITH FILTER:

1) Using CRO:

V_r (V)	V_m (V)	$V_{dc} =$ $V_m - V_r / 2$	$V_{r(rms)} =$ $V_r / 2\sqrt{3}$	R.F = $V_{r(rms)} /$ V_{dc}

2) Using DMM:

V_{AC}	V_{DC}	R.F = V_{AC} / V_{DC}

MODEL GRAPHS:

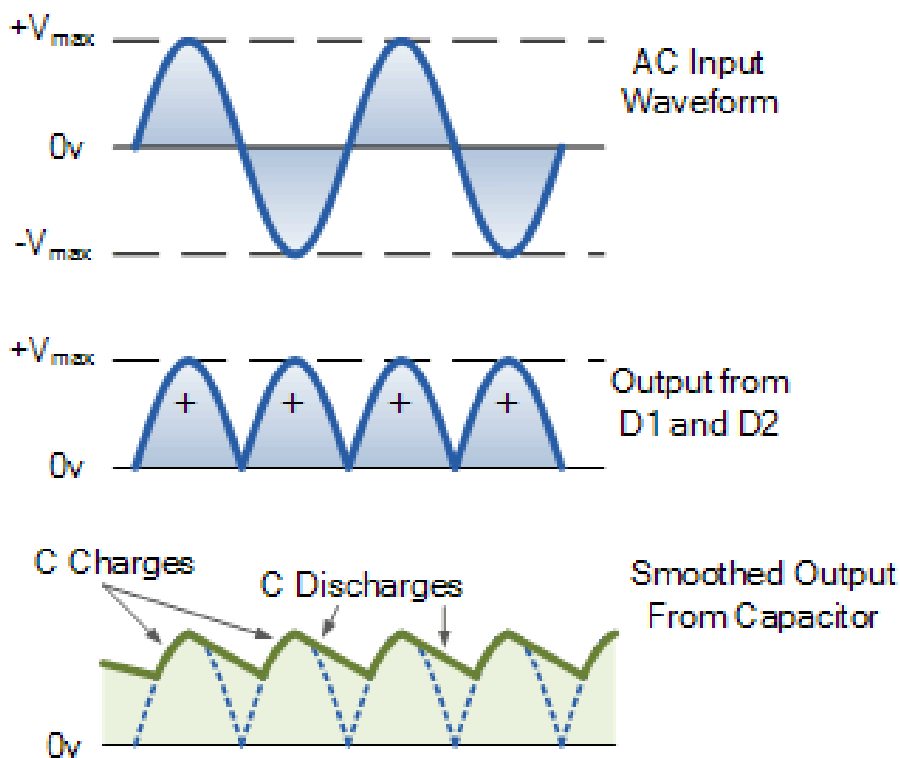

PROCEDURE: With & Without Filter:

1. Connections are made as per the circuit diagram.
2. Observe the output waveform on CRO. Note down the peak voltage value V_M .
3. Using DMM/multimeter down the AC voltage and DC voltage.
4. Now calculate V_{dc} , V_{rms} , Ripple Factor and other parameters of Half wave rectifier according to the formulae.
5. Now connect a shunt capacitor and repeat the above process.
6. For with filter put CRO in ac mode, and find out the value of V_r . And calculate V_{dc} and $V_{r(rms)}$ and other parameters.
7. Plot the graphs.

CALCULATIONS:

Without filter:

1. $V_{dc} = 2V_m / \pi$
2. $V_{rms} = V_m / \sqrt{2}$
3. $V_{r(rms)} = \sqrt{V_{rms}^2 - V_{dc}^2}$
4. Ripple Factor $r = (V_r)_{rms} / V_{dc}$

With filter:

1. $V_{dc} = V_m - V_r/2$
2. $(V_r)_{rms} = V_r/2\sqrt{3}$
3. Ripple Factor $r = (V_r)_{rms} / V_{dc}$

Theoretical Calculation: $R.F = 1/(4\sqrt{3}fCR)$

PRECAUTIONS:

1. Avoid loose and wrong connections
2. Avoid parallax error.

RESULT: The output waveforms are observed and Ripple factor of a Full wave rectifier with filter and without filter are obtained as

1. Ripple factor of full wave rectifier without filter =
2. Ripple factor of full wave rectifier with filter =

VIVA QUESTIONS:

1. What is a full wave rectifier?
2. How Diode acts as a rectifier?
3. What is the significance of PIV requirement of Diode in full-wave rectifier?
4. Compare capacitor filter with an inductor filter?
5. Draw the o/p wave form without filter? Draw the O/P? What is wave form with filter?
6. What happens to the o/p wave form if we increase the capacitor value? What happens if we increase the capacitor value?
7. What is meant by ripple factor? For a good filter whether ripple factor should be high or low? What happens to the ripple factor if we insert the filter?
8. What is meant by regulation? Why regulation is poor in the case of inductor filter?
9. What is the theoretical maximum value of ripple factor for a full wave rectifier?

PREPARED BY	CHECKED BY	H.O.D
-------------	------------	-------

7. CHARACTERISTICS OF BJT IN CB CONFIGURATION, h-PARAMETERS

AIM: To plot the input and output characteristics of a transistor in CB Configuration and to compute the h - parameters.

APPARATUS:

1. (0-30) V TRPS -----2no.s
2. $1K\Omega$ resistors -----2no.s
3. (0-100) mA ammeters ----- 2no.s
4. (0-2) V & (0-20) V Voltmeters -----1no. (each)
5. BC 107 transistor-----1no.
6. Bread Board
7. Connecting wires.

CIRCUIT DIAGRAM:

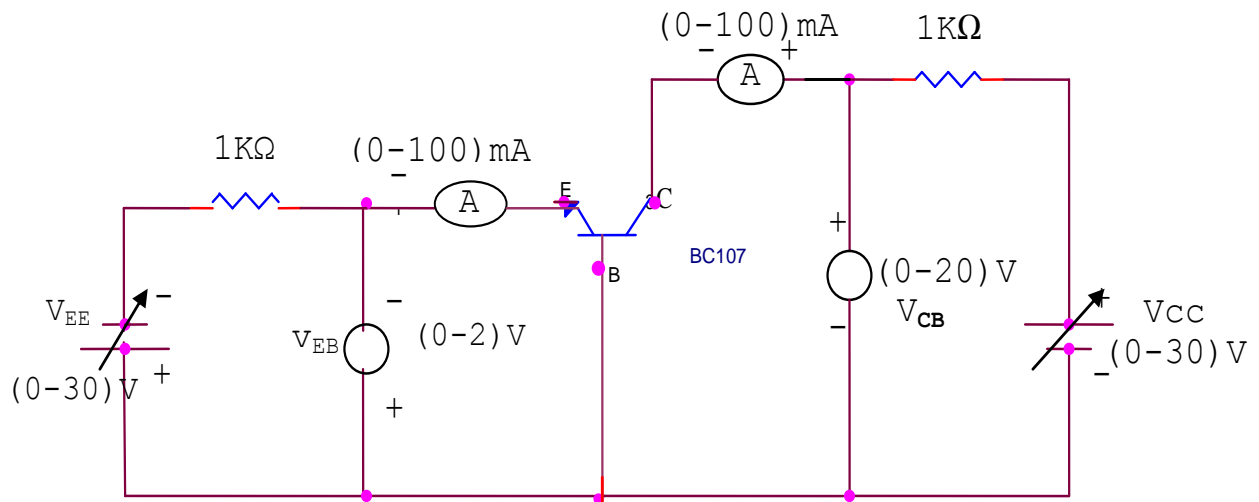

THEORY:

MODEL GRAPH: INPUT CHARACTERISTICS:

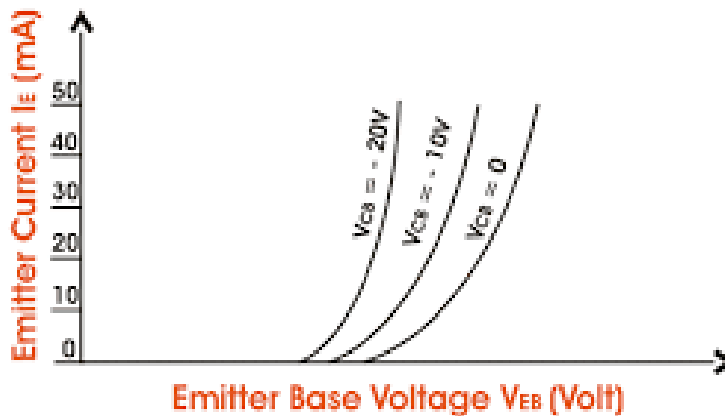

TABULAR COLUMN: INPUT CHARACTERISTICS:

$V_{CB} = 0V$		$V_{CB} = 5V$		$V_{CB} = 10V$	
$V_{BE} (V)$	$I_E (mA)$	$V_{BE} (V)$	$I_E (mA)$	$V_{BE} (V)$	$I_E (mA)$

OUTPUT CHARACTERISTICS:

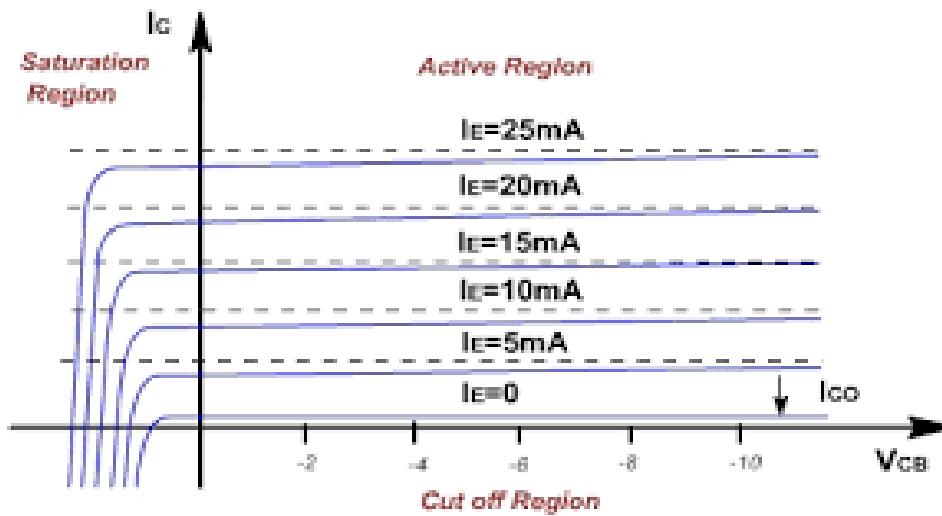

OUTPUT CHARACTERISTICS:

$I_E = 0 \text{ mA}$		$I_E = 5 \text{ mA}$		$I_E = 10 \text{ mA}$	
$V_{CB} (V)$	$I_C (mA)$	$V_{CB} (V)$	$I_C (mA)$	$V_{CB} (V)$	$I_C (mA)$

PROCEDURE:

1. Make connections as shown in circuit diagram.
2. For I/P characteristics keep V_{CB} constant at 0 V and vary voltage V_{BE} slowly in steps of 0.1 V and note down the corresponding values of I_E .
3. Repeat the same procedure for $V_{CB} = 5\text{ V}$ and $V_{CB} = 10\text{ V}$. Vary the voltage source V_2 for adjusting V_{CB} to 5 V and 10 V .
4. For O/P characteristics keep I_E constant at 0 mA and vary voltage V_{BC} vary slowly in steps of 1 V and note down the corresponding values of I_C .
5. Repeat the same procedure for $I_E = 5\text{ mA}$ and $I_E = 10\text{ mA}$. Vary the voltage source V_1 for adjusting I_E to 5 mA and 10 mA .
6. Plot the I/P & O/P characteristics and calculate the h – parameters from the graph using the formulae given below.

CALCULATIONS:

1. Input Impedance Gain $h_{ib} = \Delta V_{EB} / \Delta I_E$ at $V_{CB} = \text{constant}$
2. Reverse Voltage Gain $h_{rb} = \Delta V_{EB} / \Delta V_{CB}$ at $I_E = \text{constant}$
3. Output Admittance, $h_{ob} = \Delta I_C / \Delta V_{CB}$ at $I_E = \text{constant}$
4. Forward Current Gain, $h_{fb} = \Delta I_C / \Delta I_E$ $V_{CB} = \text{constant}$

PRECAUTIONS:

1. Connections must be made carefully to avoid short circuit.
2. Readings must be taken without parallax error.
3. The readings should not exceed the meter range.

RESULT: The input and output characteristics of transistor in CB configuration was observed and the graphs are plotted. And the h-parameters of CB configuration are obtained as $h_{ib} =$ $h_{rb} =$ $h_{ob} =$ $h_{fb} =$

VIVA QUESTIONS:

1. What is Early effect?
2. Draw the small signal model of BJT Common Base Configuration.
3. What is Reach –Through effect?
4. What are the applications of Common Base.
5. What will be the parameters of CB.
6. What is Transistor action?

PREPARED BY	CHECKED BY	H.O.D
-------------	------------	-------

8. CHARACTERISTICS OF BJT IN CE CONFIGURATION, h-PARAMETERS

AIM: To plot the input and output characteristics of a transistor in CE Configuration and to compute the h – parameters.

- APPARATUS:**
1. (0-30) V TRPS -----2no.s
 2. 1K, 300K resistors -----1no. (each)
 3. (0-100) μ A, (0-100) mA ammeters ---1no. (each)
 4. (0-2) V & (0-20) V Voltmeters -----1no. (each)
 5. BC 107 transistor-----1no.
 6. Bread Board
 7. Connecting wires.

CIRCUIT DIAGRAM:

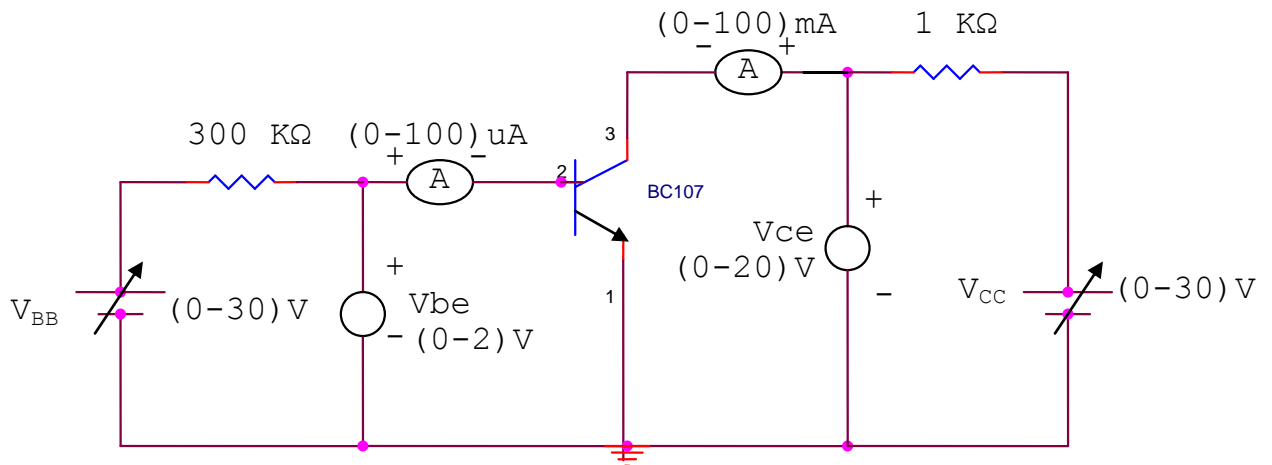

Tabular Form: INPUT CHARACTERISTICS:

$V_{CE} = 0 \text{ V}$		$V_{CE} = 5 \text{ V}$		$V_{CE} = 10 \text{ V}$	
$V_{BE} \text{ (V)}$	$I_B \text{ (}\mu\text{A)}$	$V_{BE} \text{ (V)}$	$I_B \text{ (}\mu\text{A)}$	$V_{BE} \text{ (V)}$	$I_B \text{ (}\mu\text{A)}$

**MODEL GRAPHS:
INPUT CHARACTERISTICS:**

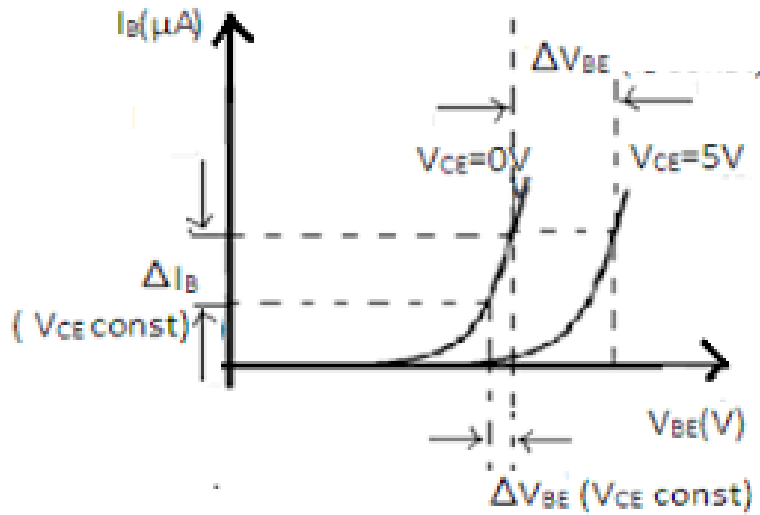

OUTPUT CHARACTERISTICS:

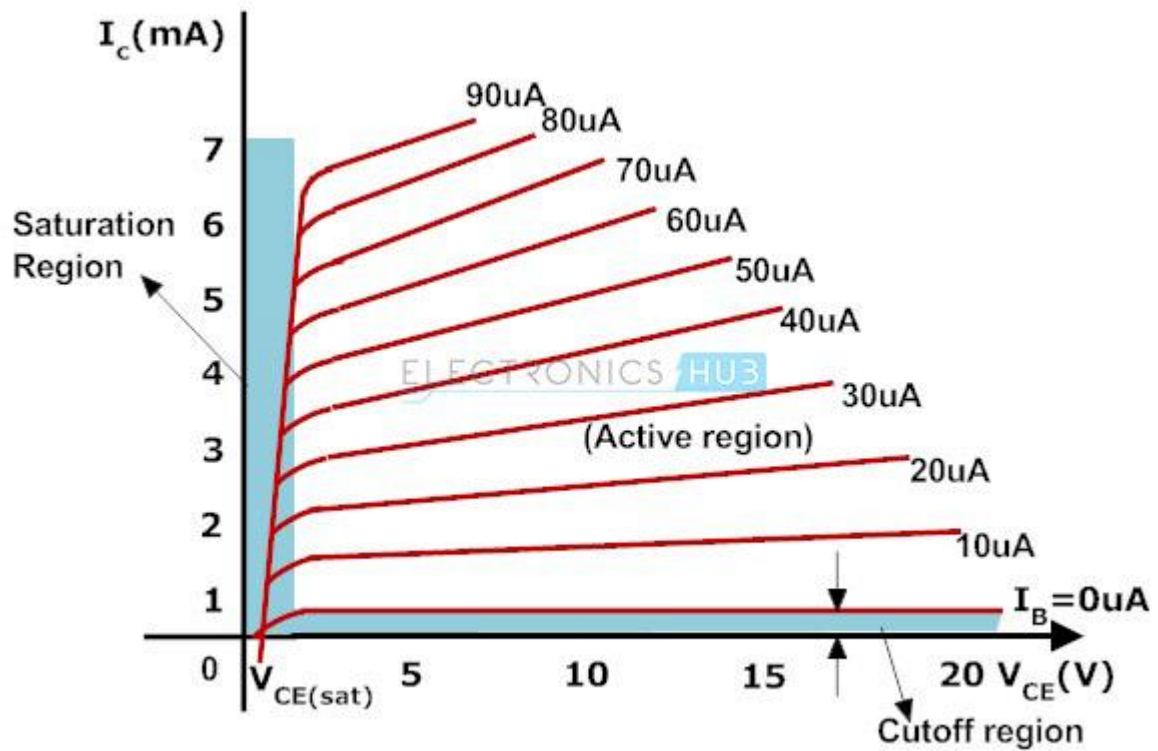

Tabular Form: OUTPUT CHARACTERISTICS:

$I_B = 0 \mu A$		$I_B = 10 \mu A$		$I_B = 20 \mu A$	
$V_{CE} (V)$	$I_C (mA)$	$V_{CE} (V)$	$I_C (mA)$	$V_{CE} (V)$	$I_C (mA)$

PROCEDURE:

1. Make connections as shown in circuit diagram.
2. For I/P characteristics keep V_{CE} constant at $0 V$ and vary voltage V_{BE} slowly in steps of $0.1 V$ and note down the corresponding values of I_B . Repeat the same procedure for $V_{CE} = 5 V$ and $V_{CE} = 10 V$. Vary the voltage source V_2 for adjusting V_{CE} to $5 V$ and $10 V$.
3. For O/P characteristics keep I_B constant at $0 \mu A$ and vary voltage V_{CE} slowly in steps of $1 V$ and note down the corresponding values of I_C . Repeat the same procedure for $I_B = 10 \mu A$ and $I_B = 20 \mu A$. Vary the voltage source V_1 for adjusting I_B to $10 \mu A$ and $20 \mu A$.
4. Plot the I/P & O/P characteristics and calculate the h – parameters from the graph using the formulae given below.

CALCULATIONS:

1. Input Impedance Gain $h_{ie} = \Delta V_{BE} / \Delta I_B$ at $V_{CE} = \text{constant}$
2. Reverse Voltage Gain $h_{re} = \Delta V_{BE} / \Delta V_{CE}$ at $I_B = \text{constant}$
3. Output Admittance, $h_{oe} = \Delta I_C / \Delta V_{CE}$ at $I_B = \text{constant}$
4. Forward Current Gain, $h_{fe} = \Delta I_C / \Delta I_B$ $V_{CE} = \text{constant}$

PRECAUTIONS:

1. Connections must be made carefully to avoid short circuit.
2. Readings must be taken without parallel or error.
3. The readings should not exceed the meter range.

RESULT: The input and output characteristics of transistor in CE configuration was observed and the graphs are plotted. And the h-parameters of CE configuration are obtained as $h_{ie} =$ $h_{re} =$ $h_{oe} =$ $h_{fe} =$

VIVA QUESTIONS:

1. Why CE configuration is most widely used?
2. Draw the equivalent circuit of C.E.
3. What is the Current Gain, voltage gain, i/p and o/p impedance in CE?.
4. Give the Relation between ' α ' and ' β ' and γ
5. Give the condition to operate the given Transistor in active, saturation & cut-off regions.
6. What is Emitter Efficiency?

PREPARED BY	CHECKED BY	H.O.D
-------------	------------	-------

9.CHARACTERISTICS OF BJT IN CC CONFIGURATION, h-PARAMETERS

AIM: To plot the input and output characteristics of a transistor in CC Configuration and to compute the h - parameters.

- APPARATUS:**
1. (0-30) V RPS -----2no.s,
 2. 1K Ω , 300K Ω resistors -----1no. (each),
 3. (0-100) μ A, (0-100) mA ammeters ---1no. (each),
 4. (0-2) V & (0-20) V Voltmeters -----1no. (each),
 5. BC 107 transistor-----1no.,
 6. Bread Board,
 7. Connecting wires

CIRCUIT DIAGRAM:

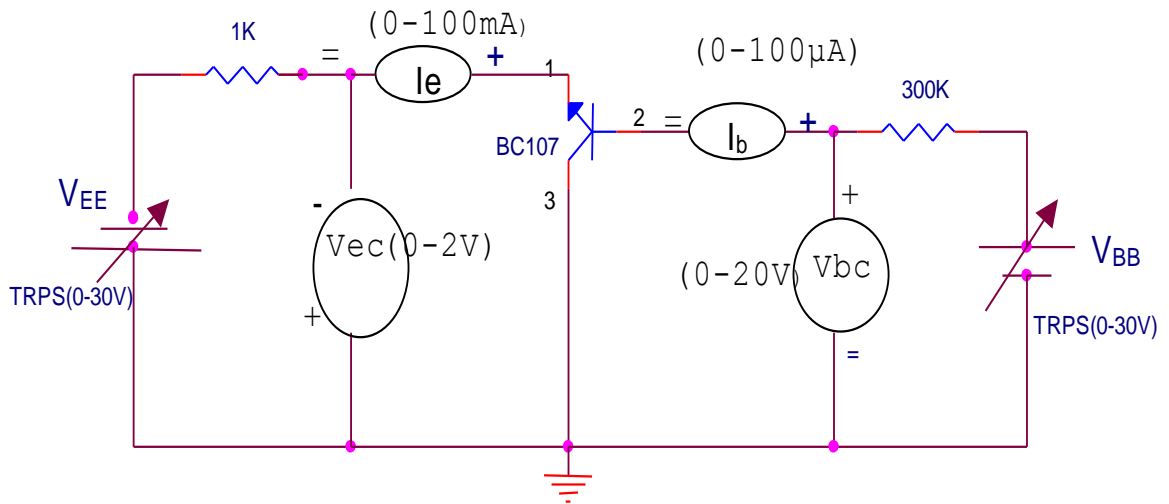

TABULAR FORM: INPUT CHARACTERISTICS:

$V_{CE} = 0V$		$V_{CE} = 5V$		$V_{CE} = 10V$	
V_{BC} (V)	I_B (μ A)	V_{BC} (V)	I_B (μ A)	V_{BC} (V)	I_B (μ A)

OUTPUT CHARACTERISTICS:

$I_B = 0 \mu\text{A}$		$I_B = 5 \mu\text{A}$		$I_B = 10 \mu\text{A}$	
$V_{CE} \text{ (V)}$	$I_E \text{ (mA)}$	$V_{CE} \text{ (V)}$	$I_E \text{ (mA)}$	$V_{CE} \text{ (V)}$	$I_E \text{ (mA)}$

PROCEDURE:

1. Make connections as shown in circuit diagram.
2. For I/P characteristics keep V_{CE} constant at 0 V and vary voltage V_{BC} slowly in steps of 0.1 V and note down the corresponding values of I_B . Repeat the same procedure for $V_{CE} = 5 \text{ V}$ and $V_{CE} = 10 \text{ V}$. Vary the voltage source V_2 for adjusting V_{CE} to 5 V and 10 V .
3. For O/P characteristics keep I_B constant at $0 \mu\text{A}$ and vary voltage V_{CE} slowly in steps of 1 V and note down the corresponding values of I_E . Repeat the same procedure for $I_B = 5 \mu\text{A}$ and $I_B = 10 \mu\text{A}$. Vary the voltage source V_1 for adjusting I_B to $5 \mu\text{A}$ and $10 \mu\text{A}$.
5. Plot the I/P & O/P characteristics and calculate the h – parameters from the graph using the formulae given below.

MODEL GRAPHS:

Input characteristics

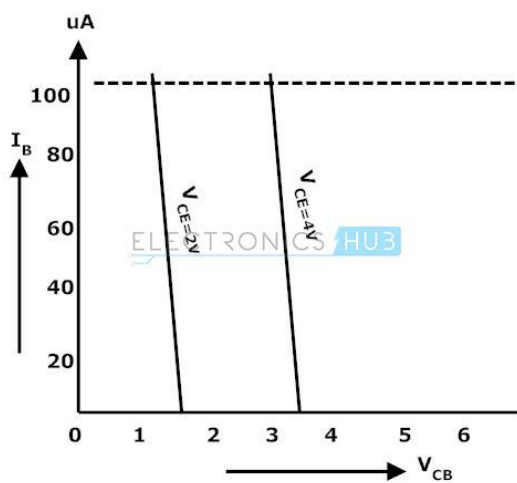

Output characteristics

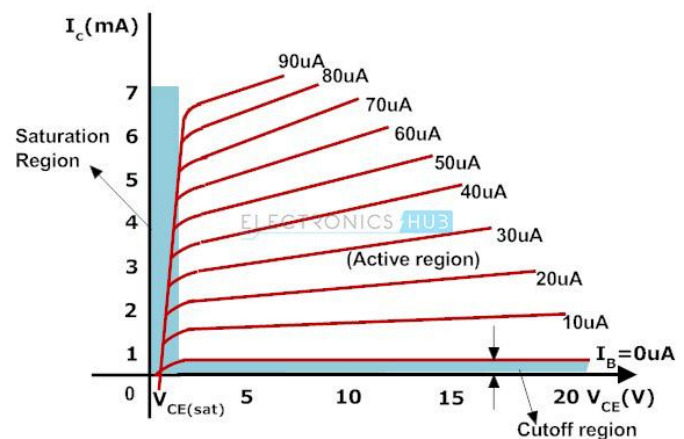

CALCULATIONS:

1. Input Impedance Gain $h_{ic} = \Delta V_{BC} / \Delta I_B$ at $V_{CE} = \text{constant}$
2. Reverse Voltage Gain $h_{rc} = \Delta V_{BC} / \Delta V_{CE}$ at $I_B = \text{constant}$
3. Output Admittance, $h_{oc} = \Delta I_E / \Delta V_{CE}$ at $I_B = \text{constant}$
4. Forward Current Gain, $h_{fc} = \Delta I_E / \Delta I_B$ $V_{CE} = \text{constant}$

PRECAUTIONS:

1. Connections must be made carefully to avoid short circuit.
2. Readings must be taken without parallel ox error.
3. The readings should not exceed the meter range.

RESULT: The input and output characteristics of transistor in CC configuration was observed and the graphs are plotted. And the h-parameters of CC configuration are obtained as $h_{ic} =$ $h_{rc} =$ $h_{oc} =$ $h_{fc} =$

VIVA QUESTIONS:

1. What is Impedance Matching?
2. Why it is called Emitter Follower?
3. Relation between α , β , γ .
4. What are the applications of C.C
5. How current gain can be increased in C.C?
6. What are the characteristics of C.C

PREPARED BY	CHECKED BY	H.O.D
-------------	------------	-------

10. DRAIN & TRANSFER CHARACTERISTICS OF J-FET CHARACTERISTICS

AIM: To plot the Drain and Transfer characteristics of a given JFET and to calculate the Drain Resistance r_d , mutual Conductance g_m & Amplification factor μ .

- APPARATUS:**
1. TRPS (0-30v)- 2no.
 2. (0-2)V & (0-20)V Voltmeters – 1no. (each),
 3. JFET BFW10-1
 4. Connecting wires
 5. Bread board
 6. $1K\Omega$ resistance.

CIRCUIT DIGRAM:

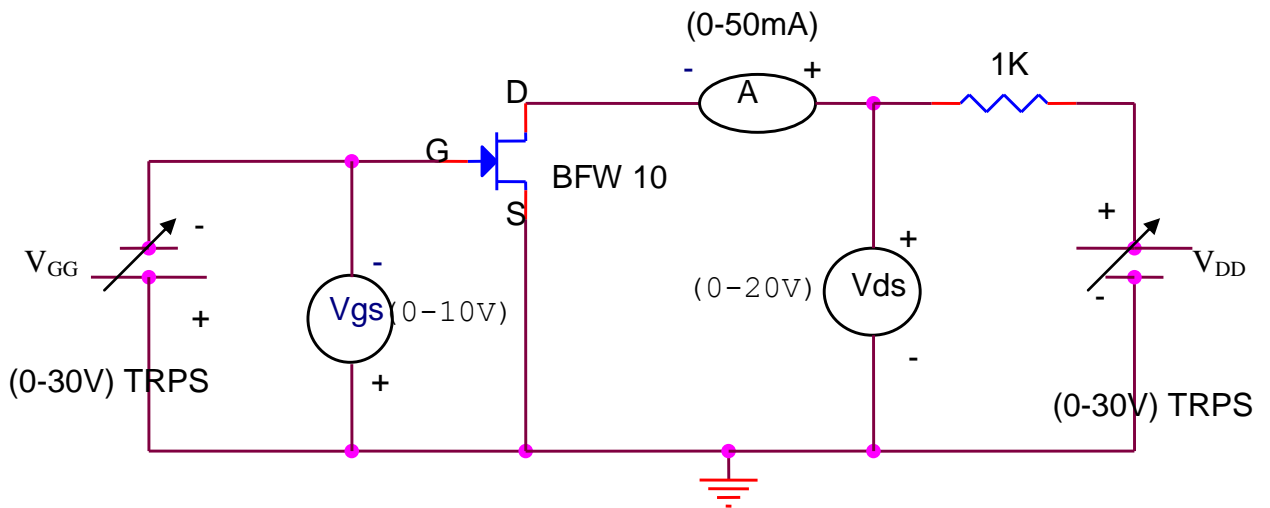

TABULAR FORM:

Drain Characteristics:

$V_{GS} = 0V$		$V_{GS} = -1V$		$V_{GS} = -2V$	
$V_{DS}(V)$	$I_D (mA)$	$V_{DS} (V)$	$I_D (mA)$	$V_{DS} (V)$	$I_D (mA)$

Transfer Characteristics:

$V_{DS} = 0.5V$		$V_{DS} = 1V$		$V_{DS} = 1.5V$	
$V_{GS} (V)$	$I_D (mA)$	$V_{GS} (V)$	$I_D (mA)$	$V_{GS} (V)$	$I_D (mA)$

MODEL GRAPHS:

Drain characteristics

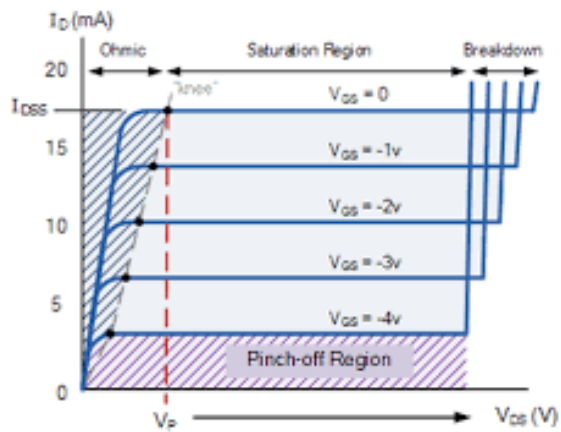

Transfer characteristics:

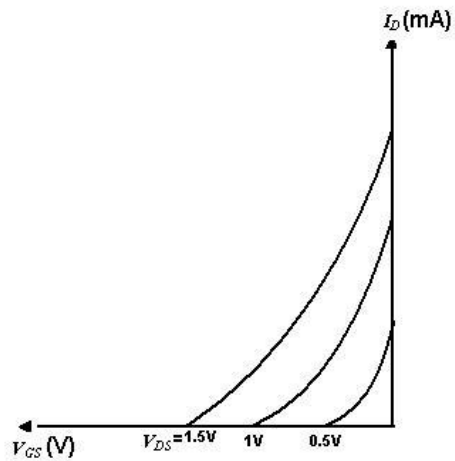

PROCEDURE:

1. Connections are made as per the circuit diagram.
2. For different fixed values of V_{GS} by varying the drain to source voltage V_{DS} the values of I_D are noted.
3. For these values the drain characteristics of the JFET are obtained.
4. For different fixed values of V_{DS} by varying the gate to source voltage V_{GS} , the values of I_D are noted.
5. From these values the transfer characteristics of the JFET are obtained.

CALCULATIONS:

1. Drain resistance (r_d) = $\Delta V_{DS} / \Delta I_D$ (Ω)
2. Mutual conductance (g_m) = $\Delta I_D / \Delta V_{GS}$
3. Amplification Factor (μ) = $r_d \times g_m$

PRECAUTIONS:

1. Connections must be made carefully to avoid short circuit.
2. Readings must be taken without parallel or error.
3. The readings should not exceed the meter range.

RESULT:

1. The Drain and transfer characteristics of a JFET are obtained and the graphs are plotted.
2. The Drain resistance, transconductance and amplification factor are obtained as $r_d =$ $g_m =$ $\mu =$

VIVA QUESTIONS:

1. What is meant by Field Effect Transistor?
2. What is meant by Unipolar and bipolar?
3. What is the difference between BJT and FET?
4. What are the characteristics of FET?
5. What is Pinch Off Voltage?
6. Why FET is called Voltage controlled Device?
7. Draw Small Signal model of FET.
8. What are the advantages of FET?

PREPARED BY	CHECKED BY	H.O.D
-------------	------------	-------

11. TRANSISTOR AS A SWITCH

AIM: To verify the switching action of a transistor and to measure the cut off and saturation voltages.

- APPARATUS:**
1. (0-30) V TRPS -----2no.s,
 2. 100K, 2.2K,100Ω,4.7K resistors ---1no. (each),
 3. (0-2) V & (0-20) V Voltmeters -----1no. (each),
 5. BC 107 transistor-----1no.,
 6. Bread Board,
 7. Connecting wires.

CIRCUIT DIAGRAM:

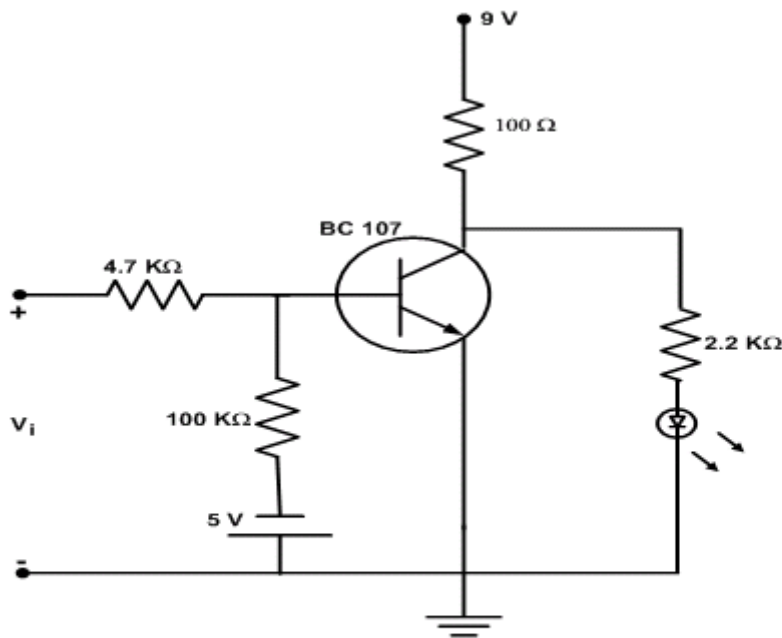

TABULAR FORM:

$V_{CE(SAT)}$	$V_{CB(SAT)}$	$V_{BE(SAT)}$	$V_{CE(cutoff)}$	$V_{CB(cutoff)}$	$V_{BE(cutoff)}$

PROCEDURE:

1. Connections are made as per the circuit diagram. $V_{ce}(\text{cutoff})$.
2. Set $V_i=0V$, Measure V_{CE}, V_{CB}, V_{BE} cutoff voltages.
3. Observe the glow of LED.
4. Set $V_i=5v$, measure V_{CE}, V_{CB}, V_{BE} Saturation voltages. LED doesn't glow

PRECAUTIONS:

1. Connections must be made carefully to avoid short circuit.
2. Readings must be taken without parallel ox error.
3. The readings should not exceed the meter range.

RESULT: The switching action of a Transistor is verified. And the saturation and cut-off values are noted as

$$V_{CE(SAT)} = \quad V_{CB(SAT)} = \quad V_{BE(SAT)} =$$
$$V_{CE(CUTOFF)} = \quad V_{CB(CUTOFF)} = \quad V_{BE(CUTOFF)} =$$

VIVA QUESTIONS:

1. What are the Modes of Operation of BJT?
2. Is BJT is a current controlled device or voltage controlled device?
3. Why phase shift occurs in BJT?
4. What is D.C. Load line?
5. How transistor acts as a switch?

PREPARED BY	CHECKED BY	H.O.D
-------------	------------	-------

12. IMPLEMENTATION OF LOGIC GATES USING DIODES AND TRANSISTORS

AIM: To verify the truth table for various logic gates using resistors, diodes and transistors.

APPARATUS:

1. Diodes IN4007-2No.
2. Transistor BC107-1no.
3. Resistor $1k\Omega$ -2no.
4. Bread board
5. Connecting wires
6. TRPS.

THEORY:

Circuits used to process digital signals are called logic gates. Gate is a digital circuit with one or more inputs but only one output. The basic gates are AND, OR, NOT, NAND, NOR. By connecting these gates in different ways we can build circuits that can perform arithmetic and other functions. The logic gates NAND, NOR are universal gates.

CIRCUIT DIAGRAMS

1. AND GATE

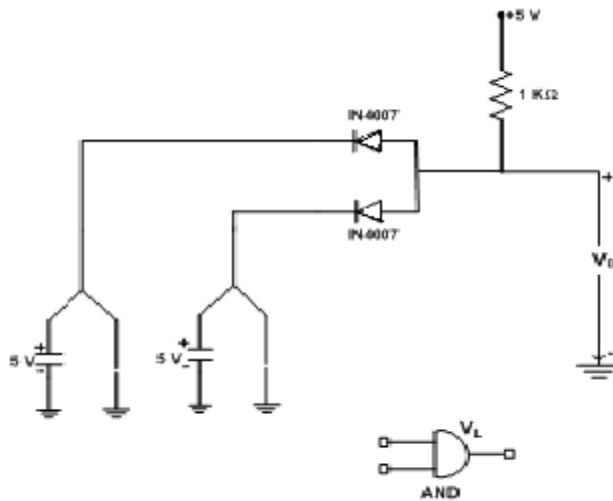

TRUTH TABLE

A	B	O/P
0	0	0
0	1	0
1	0	0
1	1	1

2. OR GATE

→

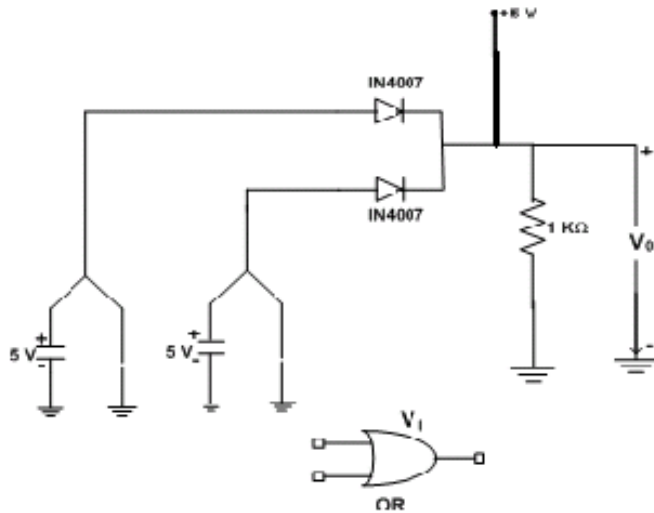

TRUTH TABLE

A	B	O/P
0	0	0
0	1	1
1	0	1
1	1	1

3. NAND GATE

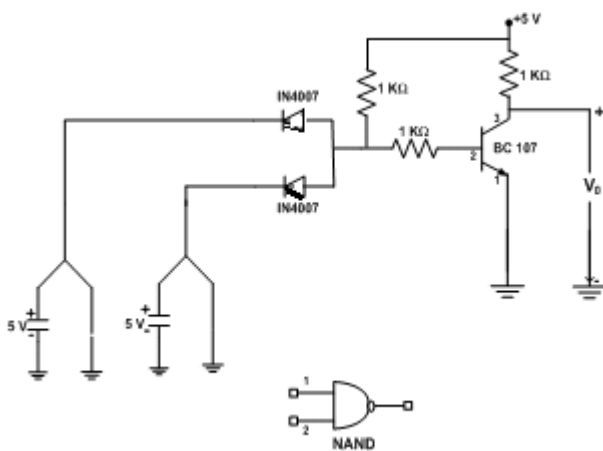

TRUTH TABLE

A	B	O/P
0	0	1
0	1	1
1	0	1
1	1	0

4. NOR GATE

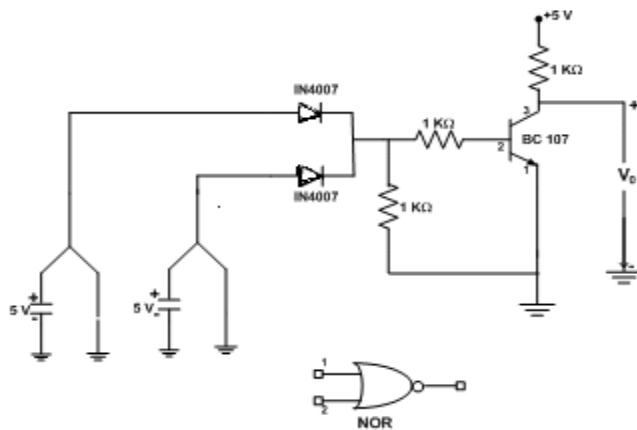

A	B	O/P
0	0	1
0	1	0
1	0	0
1	1	0

5. NOT GATE

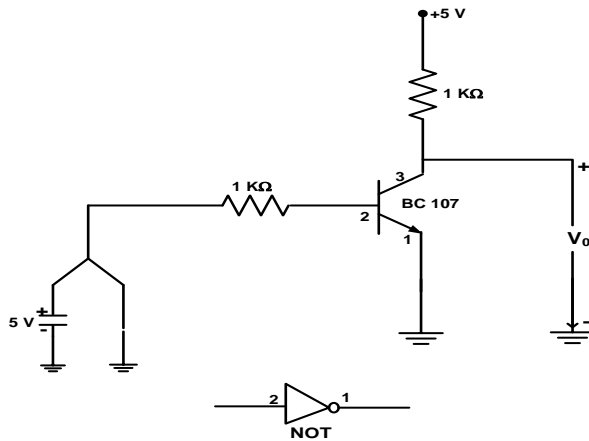

TRUTH TABLE

A	O/P
0	1
1	0

PROCEDURE:

1. Connections are made as per the circuit diagram.
2. Output is taken across the load resistance.
3. Outputs are tabulated and truth table is verified.

PRECAUTIONS:

1. Loose and wrong connections should be avoided.
2. Supply should be switched on only after giving all the input connections.
3. Power should be switched off while connecting.

RESULT: The truth table of various logic gates is verified.

VIVA QUESTIONS:

1. What are different types of logic gates?
2. What are universal gates? Why called so?
3. Explain the operation of each gate using resistors and transistors?
4. Explain logic gates using switches?
5. Draw the truth table for Exclusive OR operation.

PREPARED BY	CHECKED BY	H.O.D
-------------	------------	-------

13. SILICON-CONTROLLED RECTIFIER (SCR) CHARACTERISTICS

AIM: To plot the V-I characteristics of Silicon Controlled Rectifier.

APPARATUS: SCR (TYN616)

Regulated Power Supply (0-30V)

Resistors 10K Ω , 1K Ω -- 1no.(each)

Ammeter (0-50) μ A

Voltmeter (0-10V)

Bread board and connecting wires.

CIRCUIT DIAGRAM:

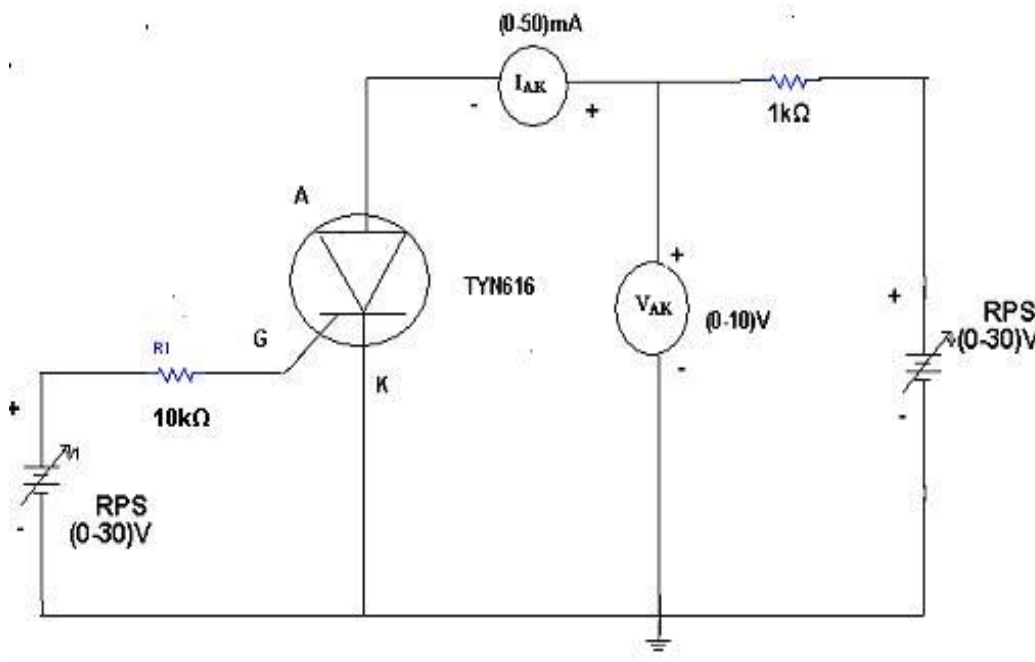

THEORY:

It is a four layer semiconductor device being alternate of P-type and N-type silicon. It consists of 3 junctions J_1, J_2, J_3 the J_1 and J_3 operate in forward direction and J_2 operates in reverse direction and three terminals called anode A, cathode K, and a gate G. The operation of SCR can be studied when the gate is open and when the gate is positive with respect to cathode.

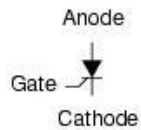

Schematic symbol

When gate is open, no voltage is applied at the gate due to reverse bias of the junction J_2 no current flows through R_2 and hence SCR is at cutt off. When anode voltage is increased J_2 tends to breakdown.

When the gate positive,with respect to cathode J_3 junction is forward biased and J_2 is reverse biased .Electrons from N-type material move across junction J_3 towards gate while holes from P-type material moves across junction J_3 towards cathode. So gate current starts flowing ,anode current increaae is in extremely small current junction J_2 break down and SCR conducts heavily.

When gate is open thee breakover voltage is determined on the minimum forward voltage at which SCR conducts heavily.Now most of the supply voltage appears across the load resistance.The holfig current is the maximum anode current gate being open , when break over occurs.

PROCEDURE:

1. Connections are made as per circuit diagram.
2. Keep the gate supply voltage at some constant value
3. Vary the anode to cathode supply voltage and note down the readings of voltmeter and ammeter. Keep the gate voltage at standard value.
4. A graph is drawn between V_{AK} and I_{AK} .

OBSERVATION:

$V_{AK}(V)$	$I_{AK} (\mu A)$

MODEL WAVEFORM:

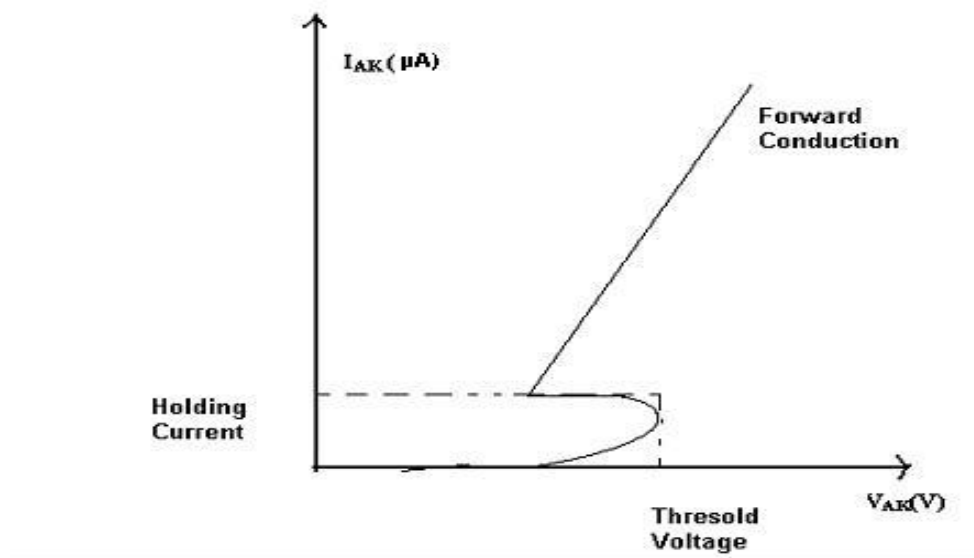

RESULT: The V-I characteristics of SCR were observed and the graph was plotted.

VIVA QUESTIONS:

1. What is the symbol of SCR?
2. In which state does SCR turn from conducting state to blocking state?
3. What are the applications of SCR?
4. What is holding current?
5. What are the important types of thyristors?
6. How many junctions are involved in SCR?
7. What is the function of gate in SCR?
8. When the gate is open, what happens when the anode voltage is increased?
9. What is the value of forward resistance offered by SCR?
10. What is the condition for making the transition from conducting state to non-conducting state?

PREPARED BY

CHECKED BY

H.O.D

14.UNIJUNCTION TRANSISTOR(UJT) CHARACTERISTICS

AIM: To obtain the V-I characteristics of UJT and plot its input negative resistance characteristics also to find its Intrinsic Standoff Ratio

APPARATUS:

Regulated Power Supply (0-30V, 1A) - 2Nos
UJT 2N2646
Resistors 1k Ω , 100 Ω
Voltmeter (0-30V) - 1no
Ammeter (0-30mA) -1no.
Breadboard and connecting Wires

THEORY:

A Unijunction Transistor (UJT) is an electronic semiconductor device that has only one junction. The UJT Unijunction Transistor (UJT) has three terminals an emitter (E) and two bases (B1 and B2). The base is formed by lightly doped n-type bar of silicon. Two ohmic contacts B1 and B2 are attached at its ends. The emitter is of p-type and it is heavily doped. The resistance between B1 and B2, when the emitter is open-circuit is called interbase resistance. The original unijunction transistor, or UJT, is a simple device that is essentially a bar of N type semiconductor material into which P type material has been diffused somewhere along its length. The 2N2646 is the most commonly used version of the UJT.

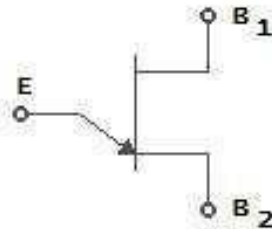

Circuit symbol

The UJT is biased with a positive voltage between the two bases. This causes a potential drop along the length of the device. When the emitter voltage is driven approximately one diode voltage above the voltage at the point where the P diffusion (emitter) is, current will begin to flow from the emitter into the base region. Because the base region is very lightly doped, the additional current (actually charges in the base region) causes (conductivity modulation) which reduces the resistance of the portion of the base between the emitter junction and the B2 terminal. This reduction

in resistance means that the emitter junction is more forward biased, and so even more current is injected. Overall, the effect is a negative resistance at the emitter terminal.

This is what makes the UJT useful, especially in simple oscillator circuits. When the emitter voltage reaches V_p , the current starts to increase and the emitter voltage starts to decrease. This is represented by negative slope of the characteristics which is referred to as the negative resistance region, beyond the valley point, R_{B1} reaches minimum value and this region, V_{EB} proportional to I_E .

CIRCUIT DIAGRAM:

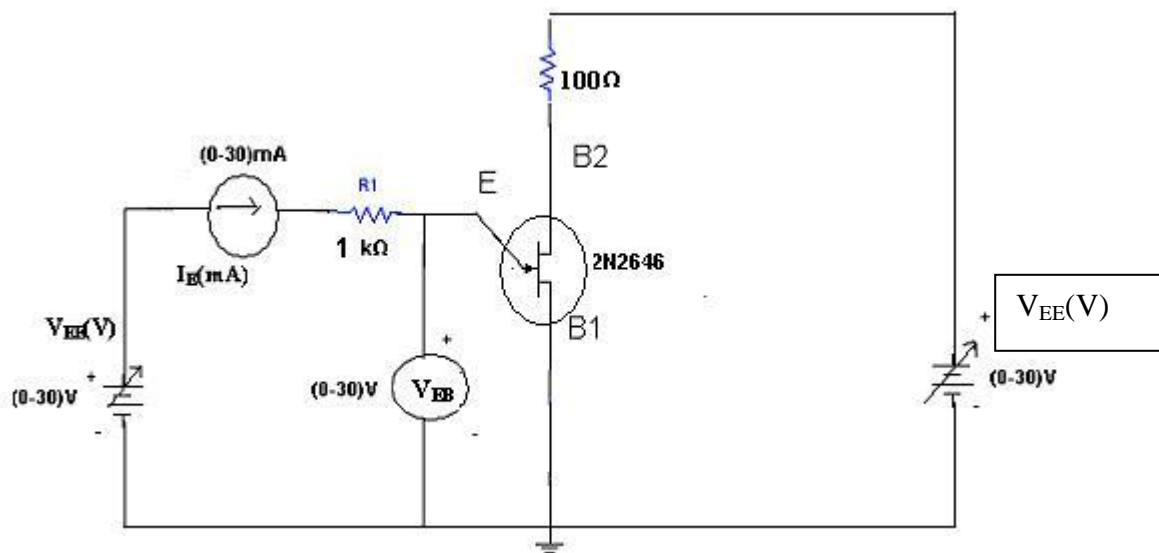

PROCEDURE:

1. Connection is made as per circuit diagram.
2. Output voltage is fixed at a constant level and by varying input voltage corresponding emitter current values are noted down.
3. This procedure is repeated for different values of output voltages.
4. All the readings are tabulated and Intrinsic Stand-Off ratio is calculated using $\eta = (V_p - V_D) / V_{BB}$
5. A graph is plotted between V_{EE} and I_E for different values of V_{BE} .

MODEL GRAPHS:

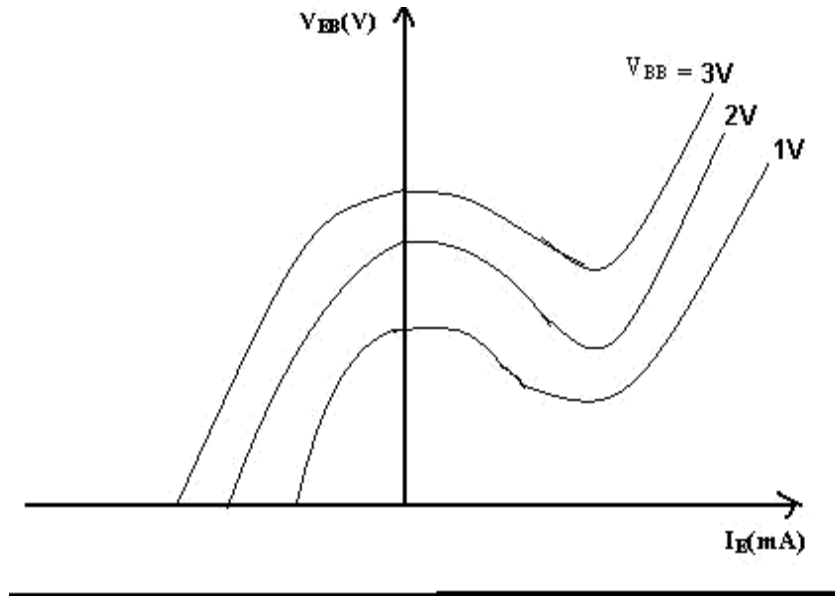

OBSERVATIONS:

$V_{BB}=1V$		$V_{BB}=2V$		$V_{BB}=3V$	
$V_{EB}(V)$	$I_E(mA)$	$V_{EB}(V)$	$I_E(mA)$	$V_{EB}(V)$	$I_E(mA)$

CALCULATIONS:

$$V_P = \eta V_{BB} + V_D$$

$$\eta = (V_P - V_D) / V_{BB}$$

$$\eta = (\eta_1 + \eta_2 + \eta_3) / 3$$

RESULT: The V-I characteristics of UJT are observed and its input negative resistance characteristics are plotted. And also its Intrinsic Standoff Ratio is obtained as $\eta =$

VIVA QUESTIONS:

1. What is the symbol of UJT?
2. Draw the equivalent circuit of UJT?
3. What are the applications of UJT?

4. Formula for the intrinsic standoff ratio?
5. What does it indicates the direction of arrow in the UJT?
6. What is the difference between FET and UJT?
7. Is UJT is used an oscillator? Why?
8. What is the Resistance between B_1 and B_2 is called as?
9. What is its value of resistance between B_1 and B_2 ?
10. Draw the characteristics of UJT?

PREPARED BY	CHECKED BY	H.O.D
-------------	------------	-------